

## CHRYSLER, DODGE, JEEP

(SKREEM, No T-Harness)

Functional if equipped | Fonctionnelle si le véhicule en est équipé.

VEHICLE   VEHICULES	YEARS ANNÉES	Lock	Unlock	Arm	Disarm	Hatch (open)	Trunk (open)	Sliding Door	Window Roll Down	Gas Door	RAP Disable	Parking Light	Memory Driver	Tachometer	Heated Seats	Heated Mirrors	Rear Defrost	Door Status	Trunk Status	Hood Status	Hand-Brake Status	Foot-Brake Status	Transponder Bypass	PK3, Passlock
		A	B	C	D	E	F	G	H	I	J	K	L	M	N	P	Q	R	S	T	U	V	W	X
<b>CHRYSLER</b>																								
200	2011-2013	•	•	•	•	•	•				•			•				•	•	•	•	•	•	•
Aspen	2007-2009	•	•	•	•	•	•				•			•				•	•	•	•	•	•	•
Crossfire	2008	•	•	•	•	•	•				•			•				•	•	•	•	•	•	•
Sebring	2008-2010	•	•	•	•	•	•				•			•				•	•	•	•	•	•	•
<b>DODGE</b>																								
Avenger	2008-2013	•	•	•	•	•	•				•			•				•	•	•	•	•	•	•
Caliber	2008-2012	•	•	•	•	•	•				•			•				•	•	•	•	•	•	•
Dakota	2007-2012	•	•	•	•	•	•				•			•				•	•	•	•	•	•	•
Durango	2007-2009	•	•	•	•	•	•				•			•				•	•	•	•	•	•	•
Nitro	2007-2011	•	•	•	•	•	•				•			•				•	•	•	•	•	•	•
RAM	2008	•	•	•	•	•	•				•			•				•	•	•	•	•	•	•
<b>JEEP</b>																								
Compass	2008-2013	•	•	•	•	•	•				•			•				•	•	•	•	•	•	•
Liberty	2008-2013	•	•	•	•	•	•				•			•				•	•	•	•	•	•	•
Patriot	2008-2013	•	•	•	•	•	•				•			•				•	•	•	•	•	•	•
Wrangler	2008-2013	•	•	•	•	•	•				•			•				•	•	•	•	•	•	•



Module label | Étiquette sur le module

**Notice: Updated Firmware and Installation Guides**

Updated firmware and installation guides are posted on our web site on a regular basis. We recommend that you update this module to the latest firmware and download the latest installation guide(s) prior to the installation of this product.

**Notice: Mise à jour microprogramme et Guides d'installations**

Des mises à jour du Firmware (microprogramme) et des guides d'installation sont mis en ligne régulièrement. Vérifiez que vous avez bien la dernière version logiciel et le dernier guide d'installation avant l'installation de ce produit.



**TECH SUPPORT**  
TEL.: 514-255-HELP (4357)  
1-877-336-7797

[www.fortinbypass.com](http://www.fortinbypass.com)

WEB UPDATE | MISE À JOUR INTERNET



**ADDENDUM GUIDE**

Rev : 20130605

**DESCRIPTION | DESCRIPTIONS**

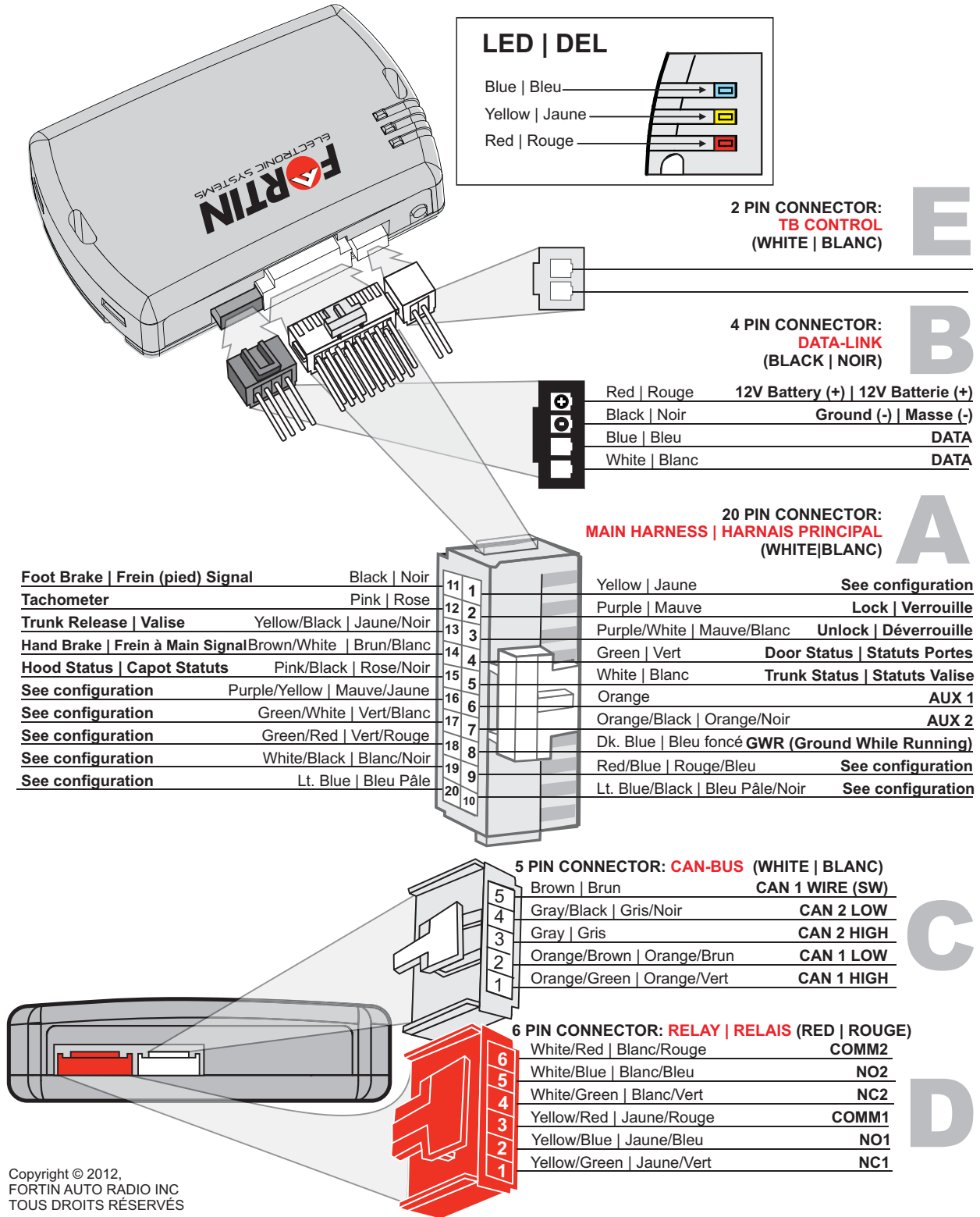

Copyright © 2012,  
FORTIN AUTO RADIO INC  
TOUS DROITS RÉSERVÉS

**VEHICLES EQUIPPED WITH AN OEM ALARM**

Some vehicles must be UNLOCKED to disarm the OEM alarm before remote start.  
Enable option #12 using the FlashLink Manager.  
When this option is enabled the module will automatically UNLOCK before remote start and LOCK after the vehicle has remote started.

**VÉHICULES ÉQUIPPÉS D'UNE ALARME D'ORIGINE**

Certains véhicules doivent être DÉVERROUILLÉS avant le démarrage à distance pour désarmer l'alarme d'origine.  
Activez l'option #12 avec le FlashLink Manager.  
Lorsque cette option est activée, le module déverrouille automatiquement avant le démarrage à distance et verrouille après que le véhicule a démarré à distance.

**WIRING CONNECTION | GUIDE DE BRANCHEMENTS**

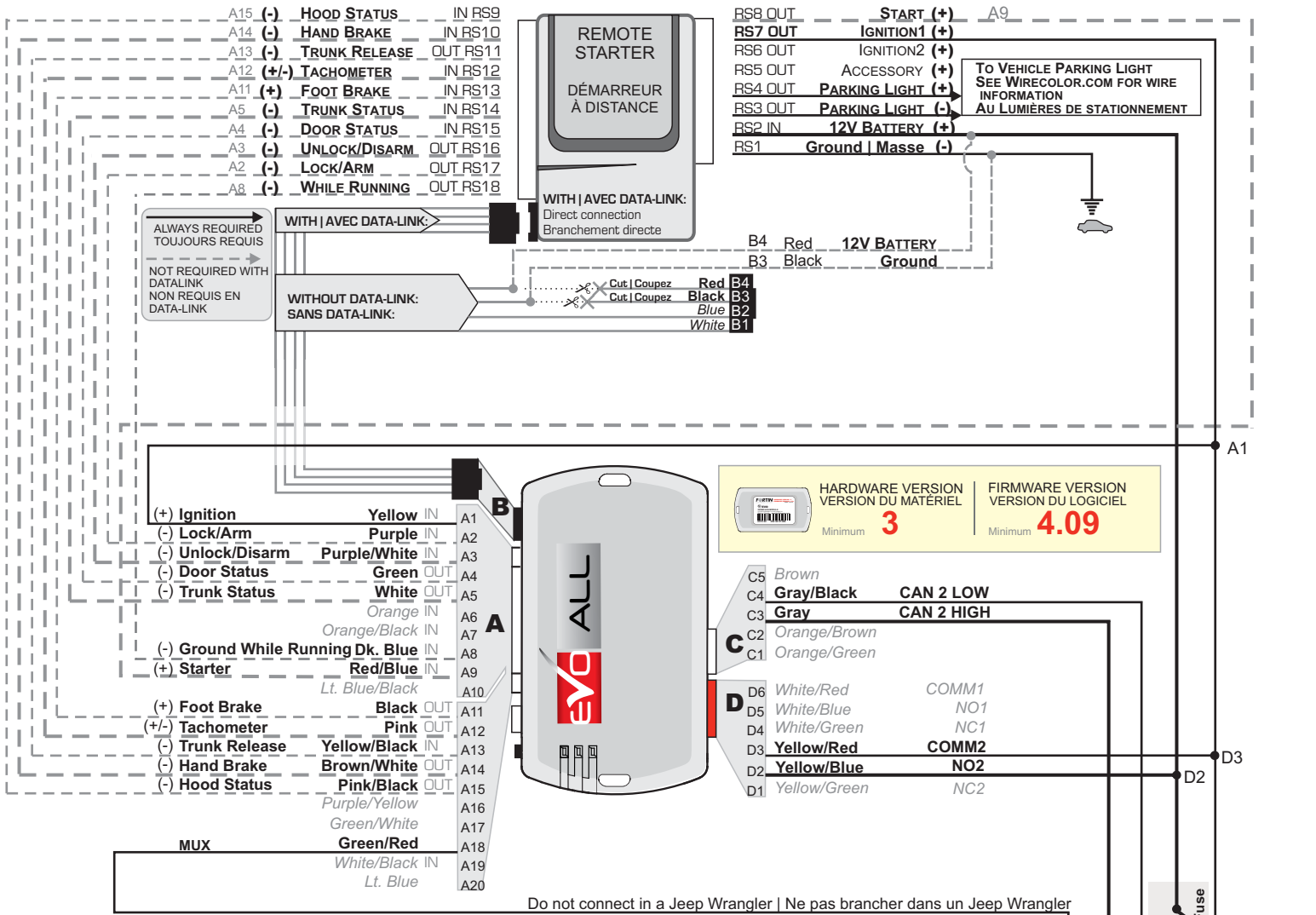

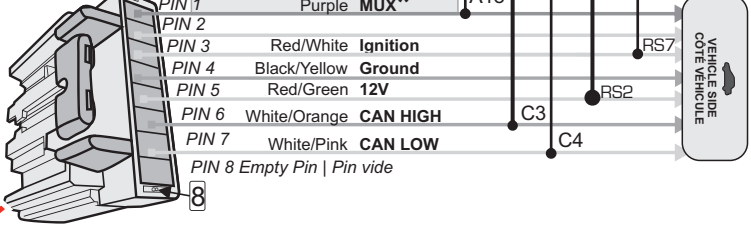

**\* PURPLE MUX**  
If the vehicle does not have a purple MUX wire : follow the connection on guide # 5061  
Si le véhicule n'a pas de fil Mauve MUX : suivez les branchements du guide # 5061



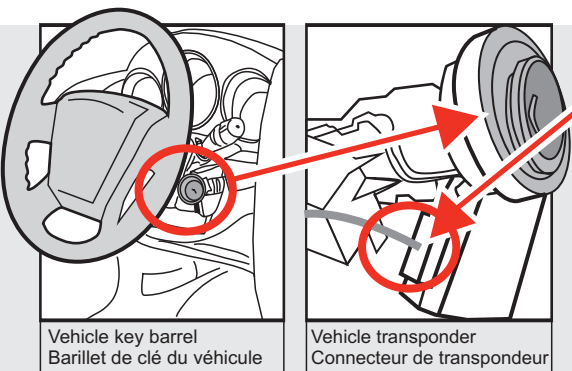



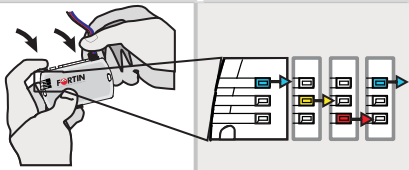
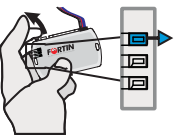

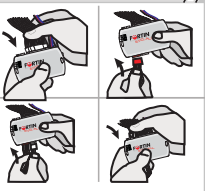

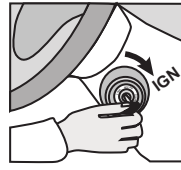
**CAUTION**  
Take care when disconnecting the harness from the ignition barrel. It is very fragile and can easily break.  
**ATTENTION** Débranchez le connecteur d'ignition avec précaution le module de l'immobilisateur est fragile.

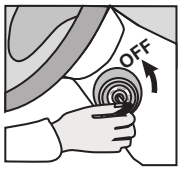

**PROGRAMMING PROCEDURE | PROCÉDURE DE PROGRAMMATION**

<p><b>1</b></p>  <p><b>Press and hold</b> the programming button:</p> <p><b>Appuyez et maintenir enfoncé</b> le bouton de programmation:</p>	 <p><b>Insert</b> the 4 Pin (Data-Link) connector.</p> <p><b>Insérez</b> le connecteur 4 pins (Data-Link).</p>	<p><i>The LED's will alternate between BLUE, YELLOW and RED flashes. Les DELS alternent entre un flash BLEU, JAUNE et ROUGE.</i></p>	 <p><b>Release</b> the programming button when the LED is <b>BLUE</b>.</p> <p><b>Relâchez</b> le bouton de programmation quand la DEL est <b>BLEU</b>.</p>	<p style="color: red; font-weight: bold;">&gt;&gt;&gt;</p> <p>If the LED is not solid BLUE disconnect the 4 Pin connector (Data-Link) and go back to beginning of step 1.   Si le DEL n'est pas BLEU solide débranchez le connecteur 4 pins (Data-Link) et allez au début de l'étape 1.</p> 	<p><b>2</b></p>  <p><b>Insert</b> the required remaining connectors: 20 pin (White), 5 pin (White), 6 pin (Red), 2 pin (White).</p> <p><b>Insérez</b> les connecteurs requis restants: 20 pins (Blanc), 5 pins (Blanc), 6 pins (Rouge), 2 pins (Blanc).</p>
---	---	--	--	---	--

<p><b>3</b></p>  <p><b>Turn</b> the Ignition to the ON/RUN position.</p> <p><b>Tournez</b> la clef en position <b>ignition (ON)</b>.</p>	<p style="text-align: center;">⏰</p>  <p><i>Flash</i></p> <p><i>The BLUE LED will flash rapidly.</i></p> <p><i>La DEL BLEU clignotera rapidement.</i></p>	 <p><b>Turn</b> the Ignition to the OFF position.</p> <p><b>Tournez</b> la clef à OFF.</p>	<p style="text-align: center;">⏰</p>  <p><i>Flash</i></p> <p><i>The BLUE LED will flash rapidly.</i></p> <p><i>La DEL BLEU clignotera rapidement.</i></p>	<p><b>5</b> With OEM remote <span style="color: red; font-weight: bold;">Or   Ou</span> Without OEM remote</p> <p>Avec Télécommande d'origine <span style="color: red; font-weight: bold;">Ou</span> Sans Télécommande d'origine</p> <div style="display: flex; justify-content: space-between;"> <div style="width: 48%;">  <p><b>Press</b> the LOCK button on the vehicles OEM remote.</p> <p><b>Appuyez</b> sur le bouton Verrouillage de la télécommande d'origine du véhicule.</p> </div> <div style="width: 48%;">  <p><b>Press and release</b> the programming button on the EVO once.</p> <p><b>Appuyez</b> sur le bouton de programmation du module EVO.</p> </div> </div>
---	--	---	--	---

<p style="text-align: center;">⏰</p>  <p><i>Off</i></p> <p><i>The BLUE LED will turn off.</i></p> <p><i>Le DEL BLEU s'éteint.</i></p>	 <p><i>The module is now programmed.</i></p> <p><i>Le module est programmé.</i></p>
--	--

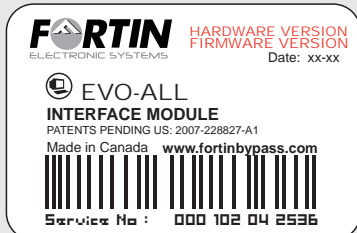

Module label | Étiquette sur le module

### Notice: Updated Firmware and Installation Guides

Updated firmware and installation guides are posted on our web site on a regular basis. We recommend that you update this module to the latest firmware and download the latest installation guide(s) prior to the installation of this product.

### Notice: Mise à jour microprogramme et Guides d'installations

Des mises à jour du Firmware (microprogramme) et des guides d'installation sont mis en ligne régulièrement. Vérifiez que vous avez bien la dernière version logiciel et le dernier guide d'installation avant l'installation de ce produit.

## WARNING

The information on this sheet is provided on an (as is) basis with no representation or warranty of accuracy whatsoever. It is the sole responsibility of the installer to check and verify any circuit before connecting to it. Only a computer safe logic probe or digital multimeter should be used. FORTIN ELECTRONIC SYSTEMS assumes absolutely no liability or responsibility whatsoever pertaining to the accuracy or currency of the information supplied. The installation in every case is the sole responsibility of the installer performing the work and FORTIN ELECTRONIC SYSTEMS assumes no liability or responsibility whatsoever resulting from any type of installation, whether performed properly, improperly or any other way. Neither the manufacturer or distributor of this module is responsible of damages of any kind indirectly or directly caused by this module, except for the replacement of this module in case of manufacturing defects. This module must be installed by qualified technician. The information supplied is a guide only. This instruction guide may change without notice. Visit [www.fortinbypass.com](http://www.fortinbypass.com) to get the latest version.

## MISE EN GARDE

L'information de ce guide est fournie sur la base de représentation (telle quelle) sans aucune garantie de précision et d'exactitude. Il est de la seule responsabilité de l'installateur de vérifier tous les fils et circuits avant d'effectuer les connexions. Seuls une sonde logique ou un multimètre digital doivent être utilisés. FORTIN SYSTÈMES ÉLECTRONIQUES n'assume aucune responsabilité de l'exactitude de l'information fournie. L'installation (dans chaque cas) est la responsabilité de l'installateur effectuant le travail. FORTIN SYSTÈMES ÉLECTRONIQUES n'assume aucune responsabilité suite à l'installation, que celle-ci soit bonne, mauvaise ou de n'importe autre type. Ni le manufacturier, ni le distributeur ne se considèrent responsables des dommages causés ou ayant pu être causés, indirectement ou directement, par ce module, excepté le remplacement de ce module en cas de défectuosité de fabrication. Ce module doit être installé par un technicien qualifié. L'information fournie dans ce guide est une suggestion. Ce guide d'instruction peut faire l'objet de changement sans préavis. Consultez le [www.fortinbypass.com](http://www.fortinbypass.com) pour voir la plus récente version.

Copyright © 2006-2012, FORTIN AUTO RADIO INC ALL RIGHTS RESERVED PATENT PENDING



## TECH SUPPORT

Tél: 514-255-HELP (4357)  
1-877-336-7797



## ADDENDUM GUIDE

[www.fortinbypass.com](http://www.fortinbypass.com)

WEB UPDATE | MISE À JOUR INTERNET

