

ADDENDUM - SUGGESTED WIRING CONFIGURATION SCHEMA DE BRANCHEMENT SUGGERÉ

		Functional if equipped Fonctionnelle si le véhicule en est équipé.																									
		Lock	Unlock	Arm	Disarm	Trunk/Hatch	Tachometer	Start/Stop control	Door status	Trunk Status	Hood Trigger	RAP Disable	Transponder Bypass	PK3, Passlock	Sliding door*	Defrost	Heated seats	Gas Door	Window Roll Down	Hatch Trigger	Foot Brake Signal	Parking Light	Hand Brake Signal	Rear Defrost	Heated Mirrors	Memory Driver	
		A	B	C	D	E	F	G	H	I	J	K	L	M	N	O	P	Q	R	S	T	U	V	W	X	Y	
VEHICLE VEHICULES	YEARS ANNÉES																										
NISSAN																											
Cube (Not push)	2009-2010	•	•			•	•	•	•	•		•									•		•				

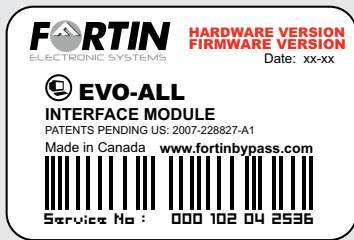

Module label | Étiquette sur le module

Notice: Updated Firmware and Installation Guides

Updated firmware and installation guides are posted on our web site on a regular basis. We recommend that you update this module to the latest firmware and download the latest installation guide(s) prior to the installation of this product.

Des mises à jour du Firmware (microprogramme) et des guides d'installation sont mises en ligne régulièrement. Vérifiez que vous avez bien la dernière version logiciel et le dernier guide d'installation avant l'installation de ce produit.

WARNING / TECH SUPPORT / MISE EN GARDE / SUPPORT TECHNIQUE

The information on this sheet is provided on an (as is) basis with no representation or warranty of accuracy whatsoever. It is the sole responsibility of the installer to check and verify any circuit before connecting to it. Only a computer safe logic probe or digital multimeter should be used. FORTIN Electronic system assumes absolutely no liability or responsibility whatsoever pertaining to the accuracy or currency of the information supplied. The installation in every case is the sole responsibility of the installer performing the work and FORTIN Electronic system assumes no liability or responsibility whatsoever resulting from any type of installation, whether performed properly, improperly or any other way. Neither the manufacturer or distributor of this module is responsible of damages of any kind indirectly or directly caused by this module, except for the replacement of this module in case of manufacturing defects. This module must be installed by qualified technician. The information supplied is a guide only. This instruction guide may change without notice. Visit www.ifar.ca to get latest version.

L'information de ce guide est fournie sur la base de représentation (telle quelle) sans aucune garantie de précision et d'exactitude. Il est de la seule responsabilité de l'installateur de vérifier tous les fils et circuit avant de effectuer les connexions. Seule une sonde logique ou un multimètre digital doivent être utilisés. FORTIN Electronic systems n'assume aucune responsabilité de l'exactitude de l'information fournie. L'installation (dans chaque cas) est la responsabilité de l'installateur effectuant le travail. FORTIN Electronic system n'assume aucune responsabilité suite à l'installation, que celle-ci soit bonne ou mauvaise ou de n'importe autre type. Ni le fabricant, ni le distributeur ne se considèrent responsables des dommages causés ou ayant pu être causés, indirectement ou directement, par ce module, excepté le remplacement de ce module en cas de défectuosité de fabrication. Ce module doit être installé par un technicien qualifié. L'information fournie dans ce guide est une suggestion. Ce guide d'instruction peut faire l'objet de changement sans préavis. Consultez le www.ifar.ca pour voir la plus récente version.

Copyright © 2006-2010, FORTIN AUTO RADIO INC ALL RIGHTS RESERVED **PATENTE PENDING**



TECH SUPPORT
Tél: 514-255-HELP (4357)
1-877-336-7797



ADDENDUM GUIDE

www.fortinbypass.com
WEB UPDATE | MISE À JOUR INTERNET



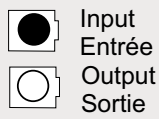

→ Connection always **required**
Branchement toujours **requis**

→ Connection **not required** with Data-link
Branchement **non requis** avec Data-Link

🚗 Connect to vehicle
Branchement au véhicule

📶 Connect to Remote-Starter/Alarm
Branchement au démarreur à distance/Alarme

**INSTALLATION WITH DATA-LINK
INSTALLATION AVEC DATA-LINK**

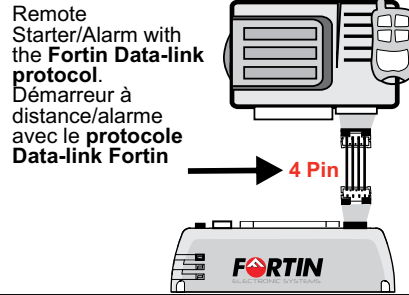

**INSTALLATION WITHOUT DATA-LINK
INSTALLATION SANS DATA-LINK**

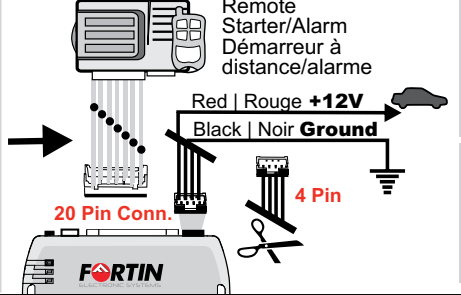

- 1 Cut off one plug of the 4 Pin Data-Link connector
- 2 Connect the Red wire to +12V
- 3 Connect the Black wire to Ground

- 1 Coupez l'extrémité du connecteur 4 pins Data-Link
- 2 Connectez le fil rouge au 12V
- 3 Connectez le fil noir à la masse du véhicule.

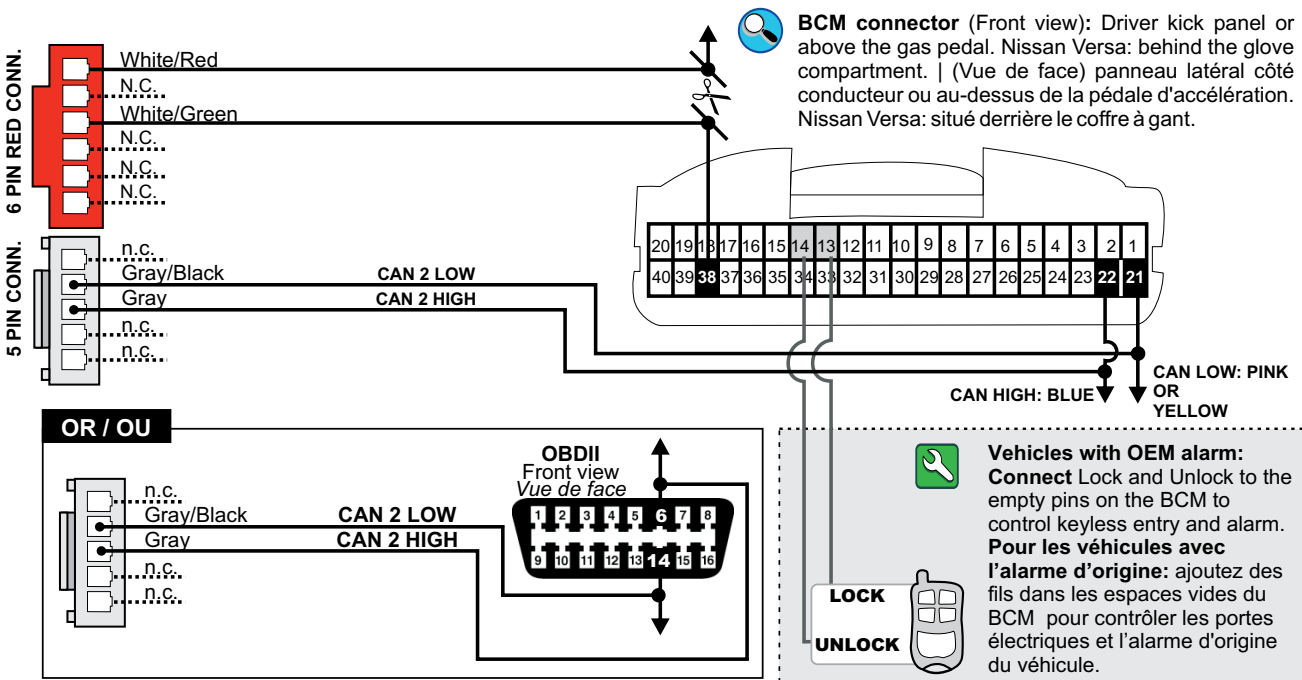
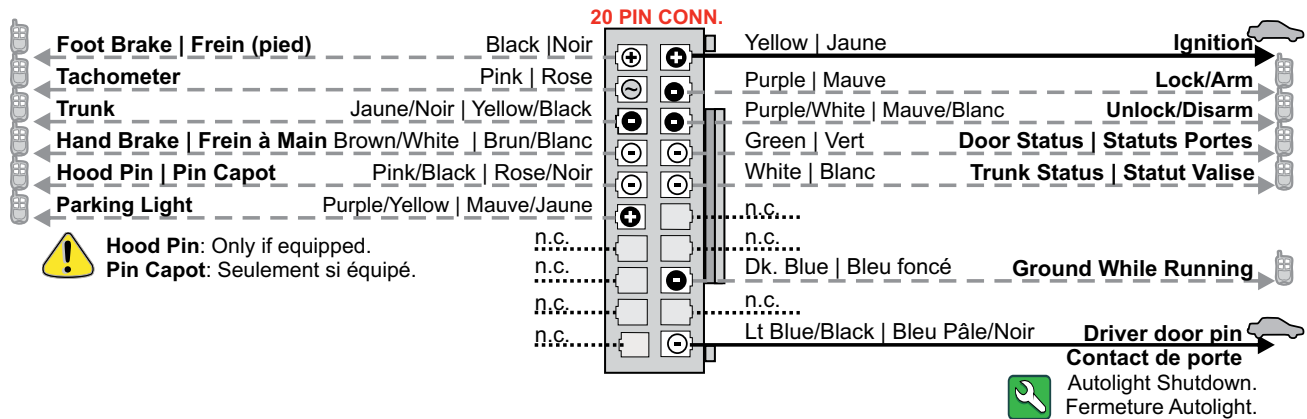

NISSAN	Starter 1	Starter 2	(+) Neutral Safety Switch
Cube	BROWN BRUN	LIGHT BLUE BLEU PÂLE	BROWN BRUN



CAUTION: Permanent damage can be done to the starter if this relay is not installed.
ATTENTION: Des dommages permanents peuvent être causés au démarreur si ce relai n'est pas installé..

**AUTOMATIC TRANSMISSION
TRANSMISSION AUTOMATIQUE**

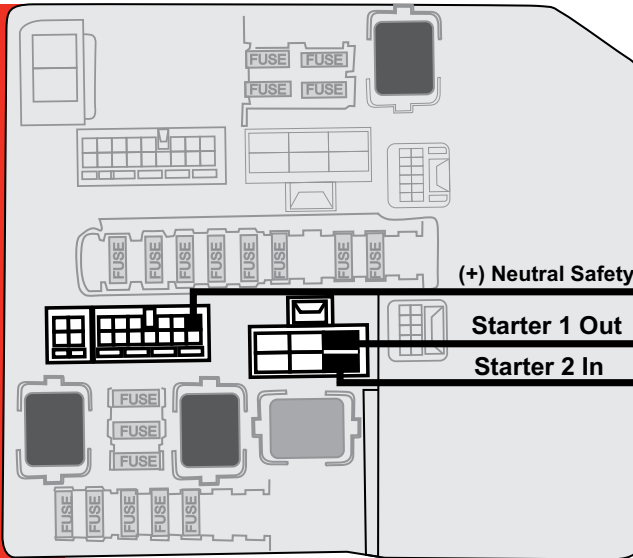

Voltage Test: (3 states) / Test de voltage: 3 états
 Key OFF: 0 Volts / Clé OFF: 0 Volts
 Key ON, Transmission in Park: 12 Volts / Clé ON Embreage a Park 12 Volts
 Key ON, Transmission in Drive: 0 Volts / Clé On Embreage a Drive: 0 Volts

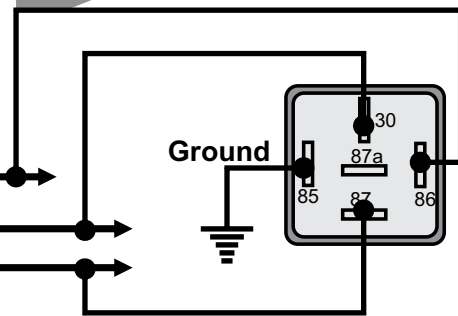

Protect the Relay from moisture otherwise damage may occur.
Protégez le Relai des intempéries. L'eau peut causer des dommages.

**MANUAL TRANSMISSION
TRANSMISSION MANUELLE**

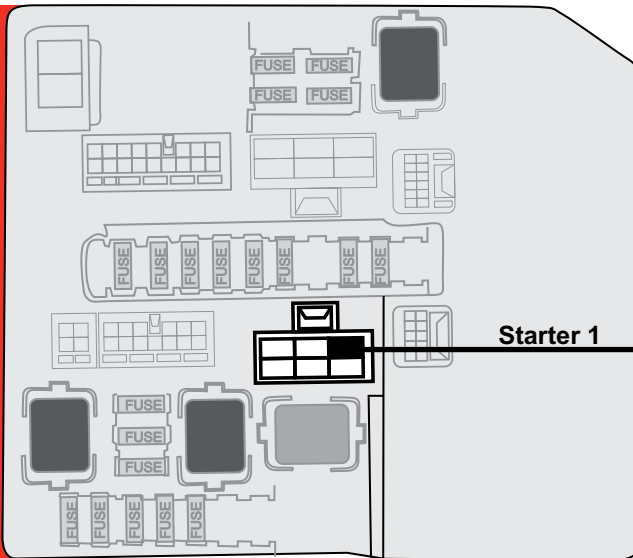

Starter 1

IPDM-E/R



Copyright © 2010, Fortin Auto Radio Inc

Copyright © 2010, Fortin Auto Radio Inc



IPDM-E/R:

Engine compartment (Batterie side)
Compartiment moteur (côté batterie)

PROGRAMMING PROCEDURE | PROCÉDURE DE PROGRAMMATION

1



Press and hold the programming button while **inserting** the 4 Pin (Data-Link) connector into the EVO-ALL module.

Pressez le bouton de programmation en insérant le connecteur 4 pins (Data-Link) dans le EVO-ALL.

2

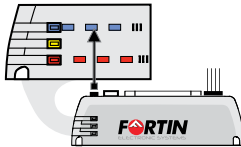

The LED will alternate between BLUE and RED flashes. **Release** the programming button when the LED is BLUE.

Les DELS alternent entre un flash BLEU et ROUGE, **relâchez** le bouton de programmation quand la DEL est BLEU.

If the LED is not solid BLUE disconnect the 4 Pin connector (Data-Link) and go back to step 1

Si le DEL n'est pas BLEU débranchez le connecteur 4 pins (Data-Link) et allez à l'étape 1.

3

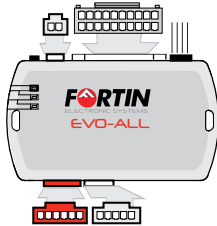

Insert the remaining connectors:

- 20 pin connector (White)
- 6 pin connector (Red)
- 5 pin connector (White)
- 2 pin connector (White)
- * If required.

Insérez les connecteurs restants:

- connecteur 20 pins.
- connecteur 6 pins.
- connecteur 5 pins
- connecteur 2 pins.
- * Si requis.

4

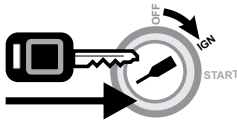

Turn the Ignition to the ON/RUN position.

Tournez la clef en position ON/RUN.

5

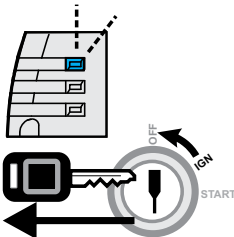

Once the LED Blue starts to flash rapidly **turn** the key to the OFF position.

Lorsque la DEL BLEU clignote rapidement, **tournez** la clef en position OFF.

The BLUE LED will turn off to indicate the module has been programmed.

La DEL BLEU s'éteint pour indiquer que le module est programmé.