

## DATA INTERFACE MODULE SELF-LEARNING FOR SECURITY SYSTEM AND / OR REMOTE STARTER.



HUMMER



### WIRING / CONNECTION GUIDE

See wiring schematic configuration

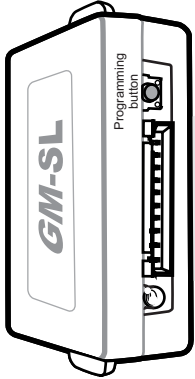

Front of the module

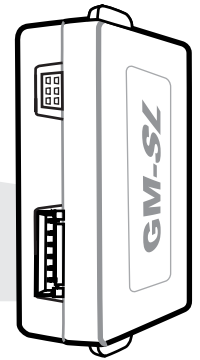
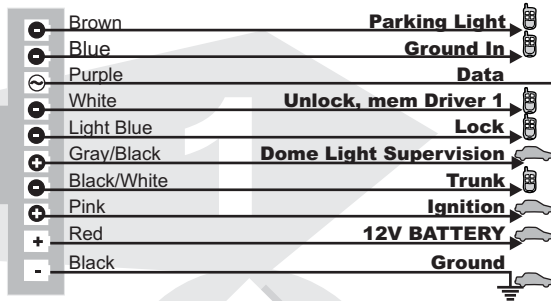

Back of the module

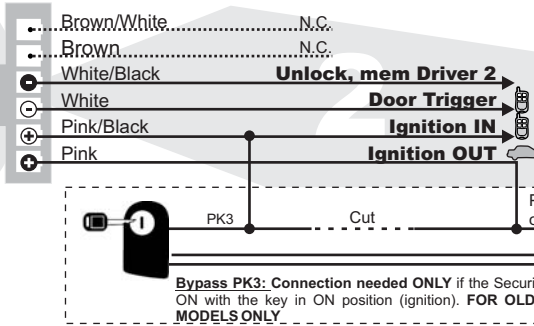

- Connect wire to vehicle
- Connect wire to Remote-Starter/Alarm
- OUTPUT ● INPUT

### START HERE

### INSTALLATION AND PROGRAMMATION INSTRUCTIONS

**1** **Make the connections of the GM-SL:**

**1.B** **Connector 1 (White, 10 pin):**  
 (I) Locate the wiring type for the vehicle on the VEHICLE FIT GUIDE (P.2)  
 (II) Make the connections associated with the vehicle in the WIRING SCHEMATIC CONFIGURATION (P.3)

**1.A** **Connector 2 (White, 6 pin):**  
 Make the connections (If necessary).

**2** Press and hold the programming button. Plug in the **connector 1** in the GM-SL interface.

**3** The LED will turn on, indicating the beginning of programming.

**4** While holding the programming button, turn the key to the ignition position.

**5** The LED will flash rapidly.

**6** Release the programming button.

**7** Start the vehicle with the key.

**8** The LED will turn off.

**9** Turn the key OFF.  
**The interface is programmed.**

**10** Plug in the **connector 2** in the GM-SL interface. (If necessary)

Special programming available on technical support internet site at [www.ifar.ca](http://www.ifar.ca) select GM-SL and installation manuals (Special Programming).

### TECHNICAL SUPPORT / INFORMATION

Neither the manufacturer or distributor of this module is responsible of damages of any kind indirectly or directly caused by this module, except for the replacement of this module in case of manufacturing defects. This module must be install by qualified technician. This instruction guide may change without notice. Visit [www.ifar.ca](http://www.ifar.ca) to get latest version.

**Technical support:**  
 TEL: 514-255-HELP (4357)  
 FAX: 514-255-1367  
 Web: [www.ifar.ca](http://www.ifar.ca)

## VEHICLE FIT GUIDE / GUIDE DES VOITURES

Vehicles / Véhicules	Years / Années	PK3, Passlock, or VATS Control	Power Windows	Power Locks	Factory Alarm Control (OEM)	Release T-Link	Door Light Supervision	Door Light (See Note 2)	Heated Seats	Heated Mirrors	Rear Defrost	Passive Light Control	Accessories	Rearmend	Memory Selection (See Note 2)	Memory Selection (See Note 2)	Memory Selection (See Note 2)	Memory Selection (See Note 2)	Memory Selection (See Note 2)	Memory Selection (See Note 2)
		A	B	C	D	E	F	G	H	I	J	K								
<b>Buick</b>	98 99 00 01 02 03 04 05 06 07																			
Century																				2
LeSabre																				2
Park Avenue																				2
Rainier																				2
Rendez-vous																				1
Terraza																				1
<b>Cadillac</b>	98 99 00 01 02 03 04 05 06 07																			
CTS																				3
DeVille																				3
DTS																				3
Escalade																				3
EXT																				3
SLS																				3
SRX																				3
STS																				3
<b>Chevrolet</b>	98 99 00 01 02 03 04 05 06 07																			
Astro																				1
Avalanche																				2
Blazer																				1
Cavalier																				1
C/K Pickup																				2
C/K Pickup Classic																				2
Corvette																				1
Express Van																				1
Impala																				1
Monte Carlo																				1
S10 - S15																				1
Silverado																				2
Silverado Classic																				2
Suburban																				2
Tahoe																				2
TrailBlazer																				2
Uplander																				1
Venture																				1
<b>GMC</b>	98 99 00 01 02 03 04 05 06 07																			
Envoy																				2
Safari																				1
Savana																				1
Sierra																				1
Sierra Classic																				2
Sonoma																				1
Yukon																				2
<b>Hummer</b>	98 99 00 01 02 03 04 05 06 07																			
H2																				2
<b>Oldsmobile</b>	98 99 00 01 02 03 04 05 06 07																			
Alero																				1
Aurora																				1
Bravada																				2
Intrigue																				2
Silhouette																				1
<b>Pontiac</b>	98 99 00 01 02 03 04 05 06 07																			
Aztek																				1
Bonneville																				3
Grand Am																				1
Montana SV6																				1
Montana																				1
Transport																				1
Sunfire																				1
<b>Saab</b>	98 99 00 01 02 03 04 05 06 07																			
9-7X																				2
<b>Saturn</b>	98 99 00 01 02 03 04 05 06 07																			
Ion																				1
Relay																				1
S Series																				1

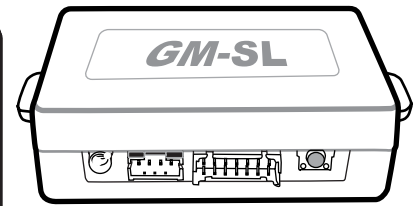

**Titres des colonnes**

- A-Contournement PK3, Passlock, ou VATS
- B-Verrouillage et déverrouillage des portes
- C-Contrôle d'Alarme d'origine (OEM)
- D-Valise
- E-Supervision lumière plafonnier
- F-Sièges et rétroviseurs chauffants
- G-Dégivreur arrière
- H-Contrôle des feux de stationnement
- I-Radio RAP accessoires
- J-Selection de mémoires conducteur 1 et 2 (par déverrouillage)
- K-Schéma de Branchements (Voir page 3)

★ :Functional with 12V Ignition only. Fonctionne avec ignition 12V seulement.

? : Not TESTED on all models, but should be functional. N'a pas été testé surtout les modèles, mais devrait fonctionner.

**Note** : Heated seats will turn ON (low power) ONLY if the engine temp is below 0°C (32°F) when remote started.

**Note** : Les sièges chauffants s'allument à faible intensité SEULEMENT si la température du moteur est sous 0°C (32°F) au démarrage.

In Data-Link mode the analog Input (unlock, ground out) are disabled for security.

En Data-Link les entrées analogues (déverrouillé, ground out) sont désactivées pour augmenter la sécurité.

**Technical support:**  
 TEL: 514-255-HELP (4357)  
 FAX: 514-255-1367  
 Web: [www.ifar.ca](http://www.ifar.ca)

This Vehicle Fit Guide may change without notice. Visit [www.ifar.ca](http://www.ifar.ca) to get latest version.  
 Ce Guide des véhicules peut faire l'objet de changement sans préavis. Consultez le [www.ifar.ca](http://www.ifar.ca) pour voir la plus récente version.

## WIRING SCHEMATIC CONFIGURATION / SCHÉMA DE BRANCHEMENT

1

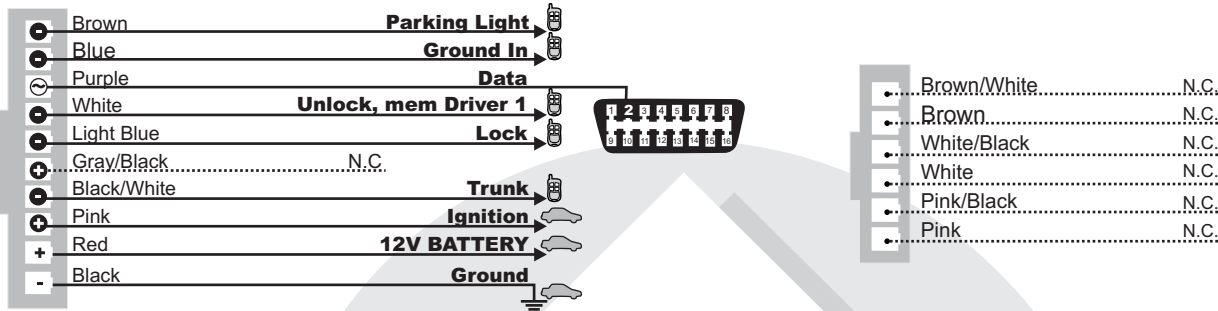

2

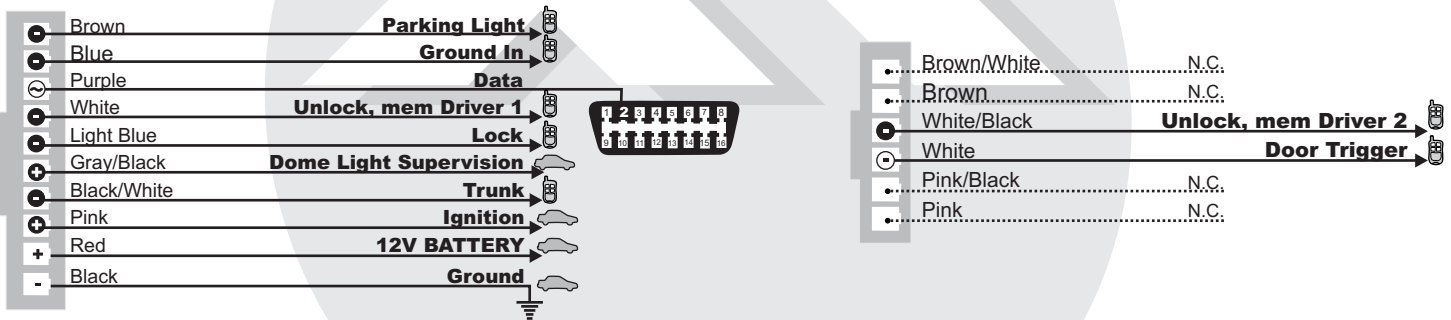

3

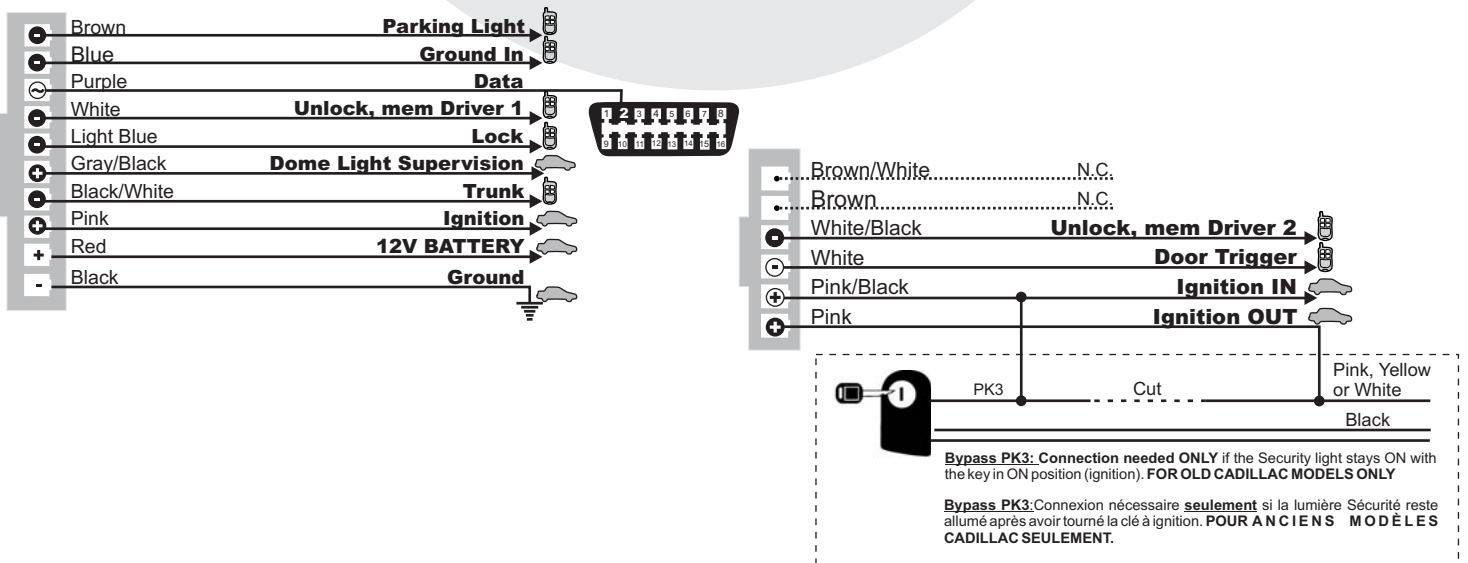

## INFORMATION

Neither the manufacturer or distributor of this module is responsible of damages of any kind indirectly or directly caused by this module, except for the replacement of this module in case of manufacturing defects. This module must be install by qualified technician. This instruction guide may change without notice. Visit [www.ifar.ca](http://www.ifar.ca) to get latest version.

Ni le manufacturier, ni le distributeur ne se considèrent responsables des dommages causés ou ayant pu être causés, indirectement ou directement, par ce module, excepté le remplacement de ce module en cas de défectuosité de fabrication. Ce module doit être installé par un technicien qualifié. Ce guide d'instruction peut faire l'objet de changement sans préavis. Consultez le [www.ifar.ca](http://www.ifar.ca) pour voir la plus récente version.

## INTERFACE DE BRANCHEMENT AUTO-APPRENTISSAGE POUR SYSTÈME DE SÉCURITÉ ET / OU DÉMARREUR À DISTANCE.



HUMMER



## CÂBLAGE / GUIDE DE CONNEXION

Voir le schéma de branchement

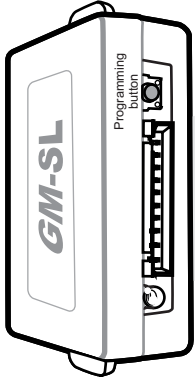

Vue de face du module

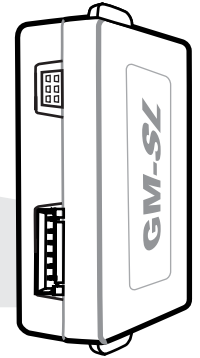

Vue de dos du module

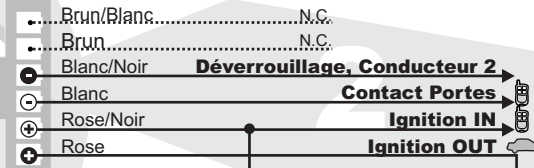

Branchement du filage au démarreur à distance/Alarme

Branchement du filage au véhicule

○ SORTIE  
● ENTRÉE

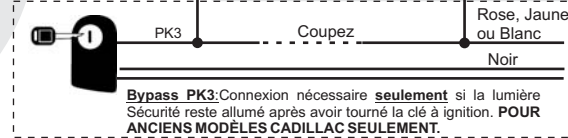

**Bypass PK3:** Connexion nécessaire seulement si la lumière Sécurité reste allumé après avoir tourné la clé à ignition. **POUR ANCIENS MODÈLES CADILLAC SEULEMENT.**

## COMMENCEZ ICI

## INSTRUCTIONS D'INSTALLATION ET DE PROGRAMMATION

**1** Effectuez les connexions du GM-SL:

**1.B** **Connecteur 2 (Blanc):**  
Déterminez le type de branchement selon votre véhicule (Voir GUIDE DES VOITURES, P.2)  
Effectuez les branchements selon le type d'installation (Voir SCHEMA DE BRANCHEMENT, P.3)

**1.A** **Connecteur 1 (Blanc, 6 branches):**  
Faites les connexions (Si nécessaire).

**2** Maintenez le bouton de programmation enfoncé. Branchez le **connecteur 1** dans le module GM-SL.

**3** Le DEL s'allume pour indiquer le début de la programmation.

**4** Ne pas relâcher le bouton de programmation et tourner la clef en position ignition.

**5** Le DEL clignote rapidement.

**6** Relâchez le bouton de programmation.

**7** Démarrez le véhicule avec la clef.

**8** Le DEL s'éteint.

**9** Tournez la clef à OFF.  
**Le module est programmé.**

**10** Branchez le **connecteur 2** dans le module GM-SL. **(Si nécessaire)**

Programmation spéciale disponible sur le site internet du support technique au [www.ifar.ca](http://www.ifar.ca) sélectionnez GM-SL et manuel d'installation (programmation spéciale).

## INFORMATIONS / SUPPORT TECHNIQUE

Ni le fabricant, ni le distributeur ne se considèrent responsables des dommages causés ou ayant pu être causés, indirectement ou directement, par ce module, excepté le remplacement de ce module en cas de défectuosité de fabrication. Ce module doit être installé par un technicien qualifié. Ce guide d'instruction peut faire l'objet de changement sans préavis. Consultez le [www.ifar.ca](http://www.ifar.ca) pour voir la plus récente version.

**Support Technique:**  
TEL: 514-255-HELP (4357)  
FAX: 514-255-1367  
Web: [www.ifar.ca](http://www.ifar.ca)