

# MULTI-IMPORT

Copyright © 2006, FORTIN AUTO RADIO INC. ALL RIGHTS RESERVED

INSTALLATION GUIDE  
Made in Canada - Rev. B - 27 / 11 / 2007  
Web site: <http://www.ifar.ca>

## TRANSPONDER BYPASS MODULE FOR GM & IMPORT VEHICLES



### WIRING / CONNECTION GUIDE

See wiring schematic configuration

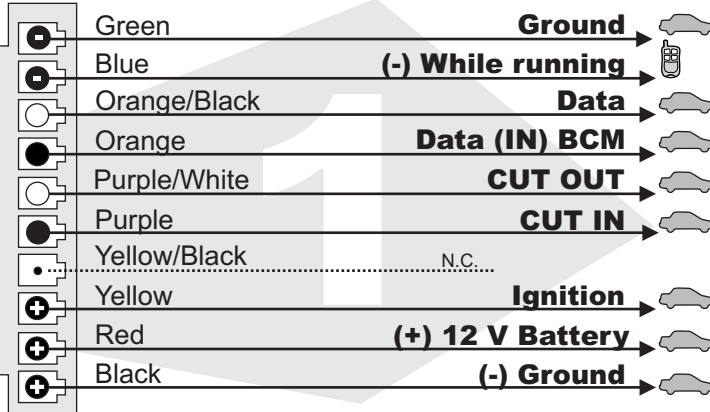
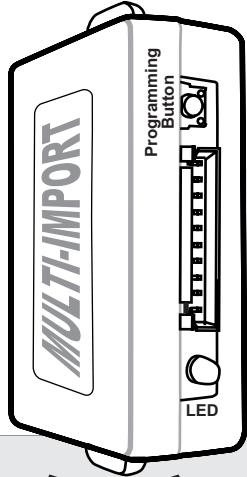

Connect wire to Remote-Starter/Alarm

Connect wire to vehicle

OUTPUT

INPUT

### START HERE

### INSTALLATION AND PROGRAMMATION INSTRUCTIONS

**1** Make the connections of the MULTI-IMPORT to the vehicle:



#### Connector 2 (White):

- (I) Locate the wiring type for the vehicle on the VEHICLE FIT GUIDE (Below)
- (II) Make the connections associated with the vehicle in the WIRING SCHEMATIC CONFIGURATION (P.2-3)

**2** Press and hold the programming button.

**3** Plug the connector into MULTI-IMPORT interface.

**4** When the LED flashes release the programming button.

**5**



Turn the key to the ignition position (ON).



**For KIA Sportage V6**, turn On and OFF ignition switch 4 times to turn the LED OFF.

**6**

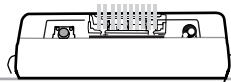

Once the LED turns off...

**7**

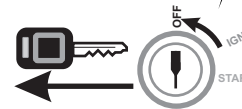

Turn the key OFF and remove the key.

**10**



Remote-Start the car.  
**The module is now programmed.**

### VEHICLE FITGUIDE

VEHICLES	YEARS OF VEHICLE COMPATIBILITY								CONFIGURATION
	01	02	03	04	05	06	07	08	
<b>Chevrolet</b>									
Aveo				●	●	●		●	1
Aveo 5 (LS)				●	●	●		●	1
Epica (LS)				●	●	●	●		2
Epica (TL)				●	●	●	●		2
<b>Hyundai</b>									
Tiburon (6 cyl.)		●	●	●	●	●	●		4
Tucson V6				●	●	●	●		5
XG300	●								3
XG350		●	●	●	●				3

VEHICLES	YEARS OF VEHICLE COMPATIBILITY								CONFIGURATION
	01	02	03	04	05	06	07	08	
<b>Kia</b>									
Sedona				●	●				6 or 7
Sorento				●	●	●	●		6
Sportage V6				●	●	●	●		5
<b>Pontiac</b>									
Wave	01	02	03	●	●	●	●	●	1
Wave 5				●	●	●	●	●	1
<b>Suzuki</b>									
Swift	01	02	03	●	●	●	●	●	1
Verona				●	●	●	●		2

### TECHNICAL SUPPORT / INFORMATION

Neither the manufacturer or distributor of this module is responsible of damages of any kind indirectly or directly caused by this module, except for the replacement of this module in case of manufacturing defects. This module must be install by qualified technician. This instruction guide may change without notice. Visit [www.ifar.ca](http://www.ifar.ca) to get latest version.

**Technical support:**  
TEL: 514-255-HELP (4357)  
FAX: 514-255-1367  
Web: [www.ifar.ca](http://www.ifar.ca)

## WIRING SCHEMATIC CONFIGURATION / SCHÉMA DE BRANCHEMENT

### 1 AVEO (LS), WAVE, SWIFT

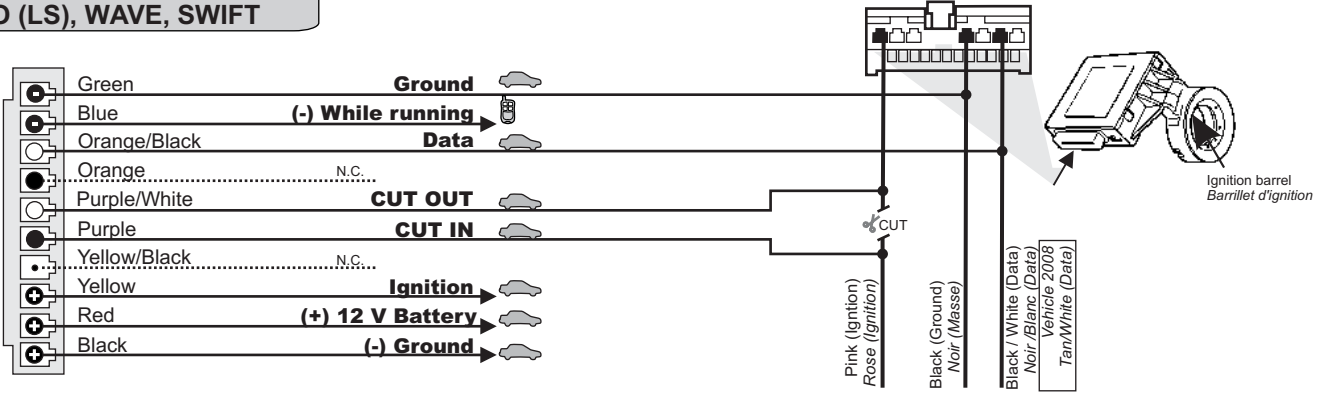

### 2 EPICA

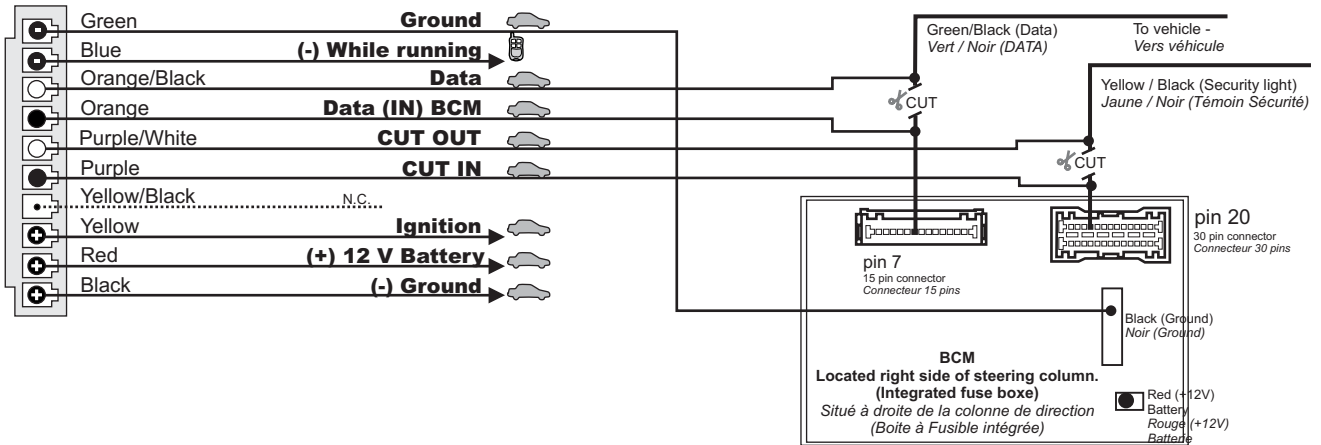

### 3 HYUNDAI XG 300 & XG 350

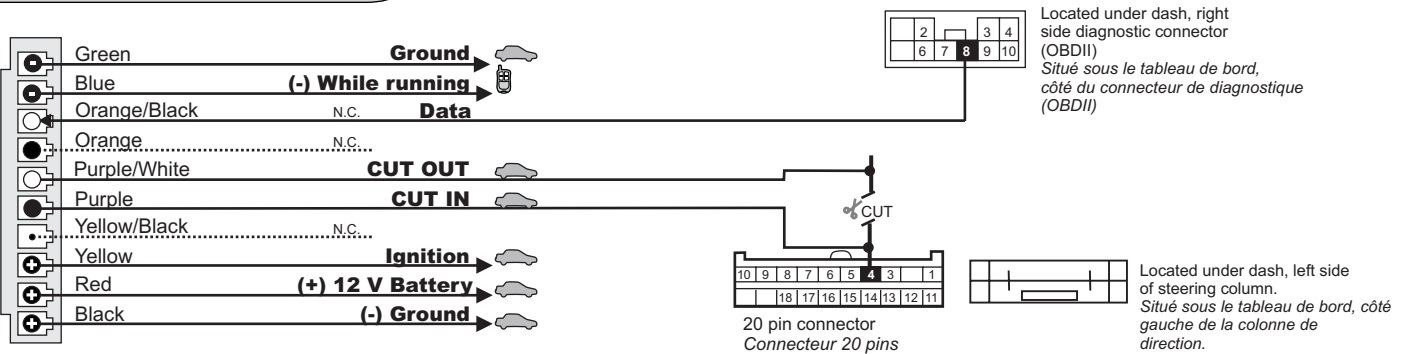

VEHICLES	DATA			SECURITY LIGHT / LUMIÈRE DE SÉCURITÉ	
	Pin	Color	Couleur	Color	Couleur
Chevrolet XG300 XG350	8	Green	Vert	Brown / White or Pink	Brun / Blanc ou Rose

### 4 TIBURON V6

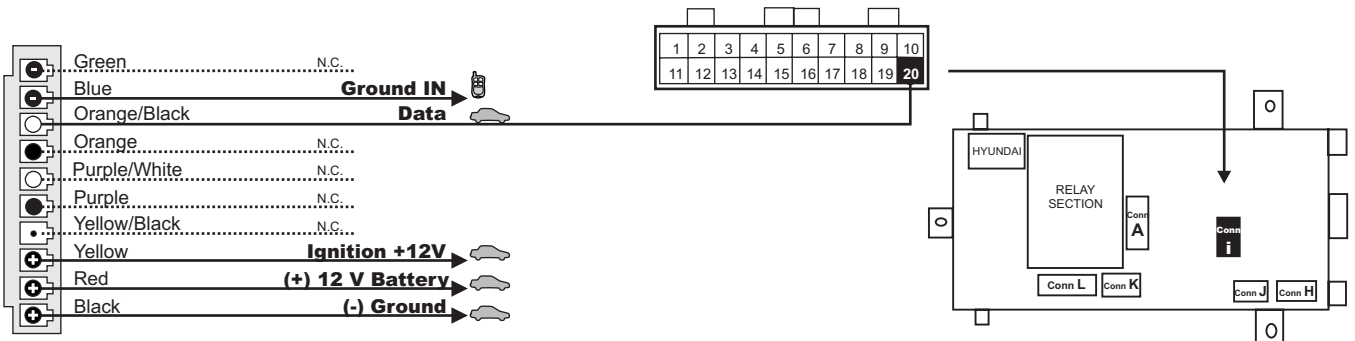

VEHICLES	DATA	LOCATION
Tiburon	Blue/Orange   Bleu/Orange	Behind Fuse Box - BCM   BCM - Derrière la boîte à fusible

## WIRING SCHEMATIC CONFIGURATION / SCHÉMA DE BRANCHEMENT

### 5 KIA Sportage 2005-2006

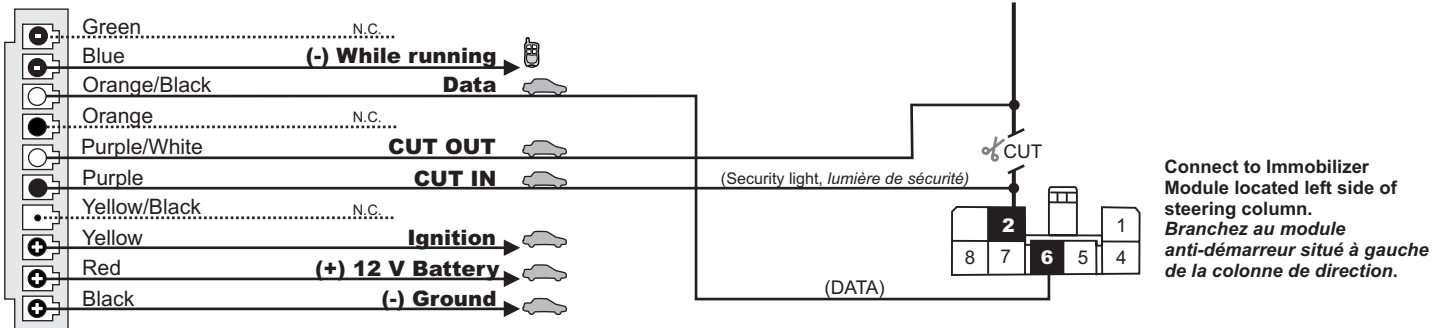

VEHICLES	DATA		SECURITY LIGHT / LUMIÈRE DE SÉCURITÉ		LOCATION
	Color	Couleur	Color	Couleur	
Chevrolet					
Sportage V6	Brown/Orange	Brun/Orange	White/Black	Blanc/Noir	8 pin connector   Connecteur 8 pin
Tucson V6	Brown/Orange	Brun/Orange	White/Black	Blanc/Noir	8 pin connector   Connecteur 8 pin

### 6 -KIA Sorento KIA Sedona 2004

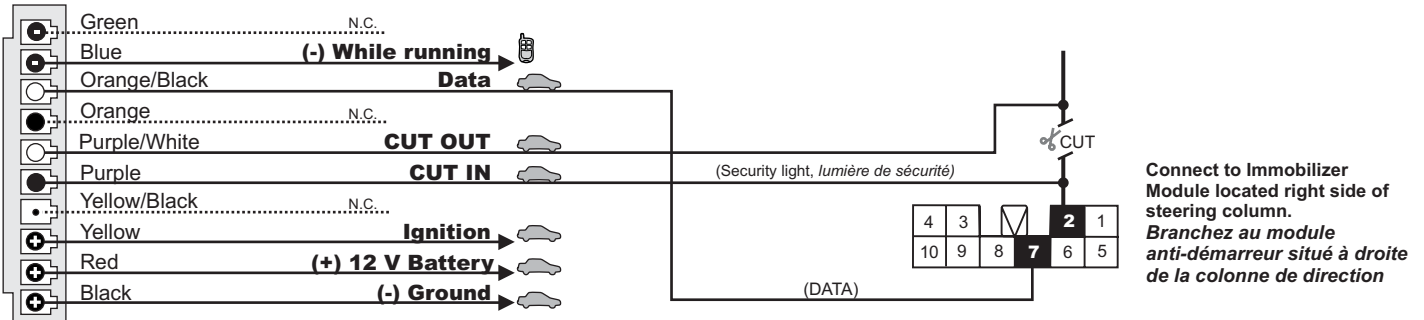

VEHICLES	Pin	DATA		SECURITY LIGHT / LUMIÈRE DE SÉCURITÉ		LOCATION
		Color	Couleur	Color	Couleur	
Chevrolet						
Sedona	7	Red	Rouge	Green or Orange	Vert ou Orange	10 pin connector   10 pin connecteur
Sorento	7	Blue	Bleu	Blue / Orange	Bleu/Orange	10 pin connector   10 pin connecteur

### 7 - KIA Sedona 2005

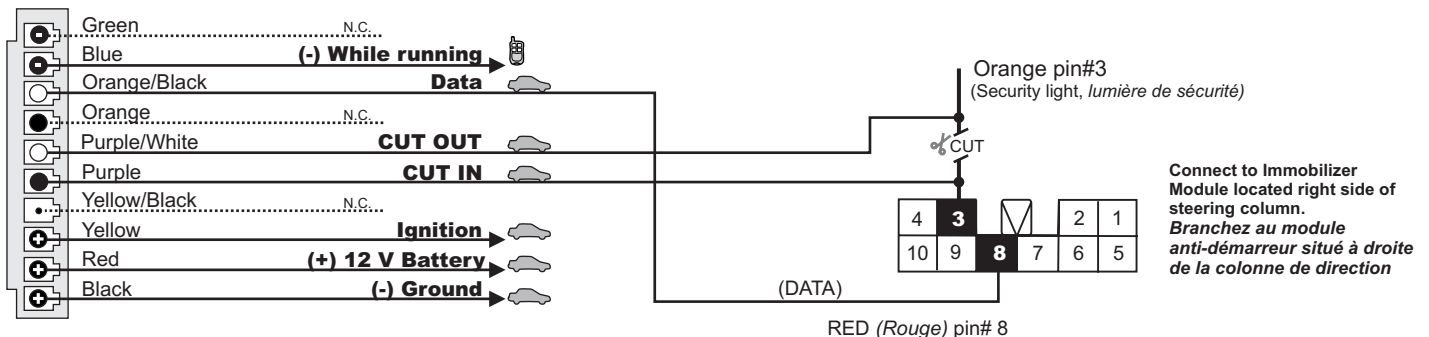

### MODULE DE CONTOURNEMENT DE TRANSPONDEUR POUR VEHICULES GM ET IMPORTÉS



### CÂBLAGE / GUIDE DE CONNEXION

Voir schéma de branchement

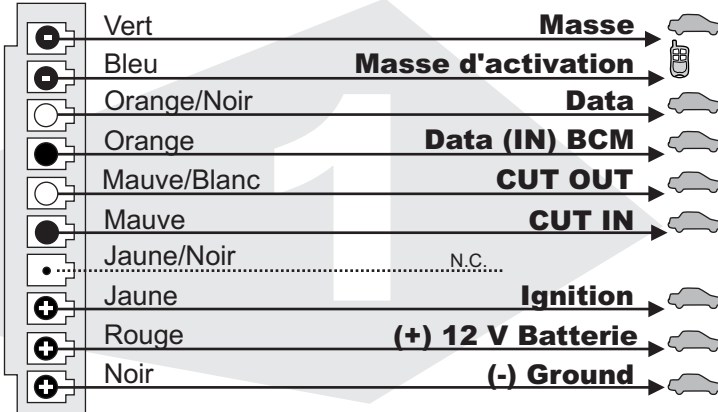
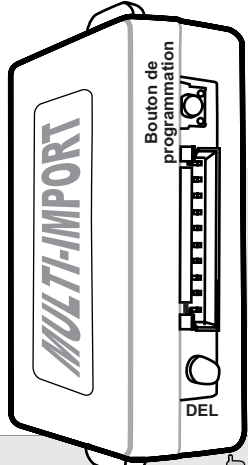

Branchement du filage au démarreur à distance/Alarme Branchement du filage au véhicule

● ENTRÉE  
○ SORTIE

### COMMENCEZ ICI

### INSTRUCTIONS D'INSTALLATION ET DE PROGRAMMATION

**1** Effectuez les connexions du MULTI-IMPORT au véhicule:

**Connecteur (Blanc):**  
Déterminez le type de branchement selon votre véhicule (Voir GUIDE DES VOITURES, ci-dessous)  
Effectuez les branchements selon le type d'installation (Voir SCHÉMA DE BRANCHEMENT, P.2-3)

**2** Maintenez le bouton de programmation enfoncé.

**3** Branchez le connecteur 1 dans le module MULTI-IMPORT.

**4** Quand le DEL clignote relâchez le bouton de programmation.

**5** Tournez la clef en position ignition (ON).

**6** Pour les véhicules KIA Sportage V6, Tournez la clef en position ignition (ON) 4 fois pour éteindre le DEL.

**7** Quand le DEL s'éteint...

**8** Tournez la clef à OFF et retirez-la.

**10** Démarrez le véhicule à distance. **LE MULTI-IMPORT EST PROGRAMMÉ.**

### GUIDE DES VÉHICULES

VÉHICULES	COMPATIBILITÉ DES ANNÉES								BRANCHEMENT
	01	02	03	04	05	06	07	08	
<b>Chevrolet</b>									
Aveo				●	●	●			1
Aveo 5 (LS)				●	●	●			1
Epica (LS)				●	●	●	●		2
Epica (TL)				●	●	●	●		2
<b>Hyundai</b>									
Tiburon (6 cyl.)		●	●	●	●	●	●		4
Tucson V6						●	●		5
XG300	●								3
XG350		●	●	●	●				3

VÉHICULES	COMPATIBILITÉ DES ANNÉES								BRANCHEMENT
	01	02	03	04	05	06	07	08	
<b>Kia</b>									
Sedona				●	●				6 or 7
Sorento				●	●	●	●		6
Sportage V6				●	●	●	●		5
<b>Pontiac</b>									
Wave				●	●	●		●	1
Wave 5				●	●	●		●	1
<b>Suzuki</b>									
Swift				●	●	●		●	1
Verona				●	●	●	●		2

### INFORMATIONS / SUPPORT TECHNIQUE

Ni le manufacturier, ni le distributeur ne se considèrent responsables des dommages causés ou ayant pu être causés, indirectement ou directement, par ce module, excepté le remplacement de ce module en cas de défectuosité de fabrication. Ce module doit être installé par un technicien qualifié. Ce guide d'instruction peut faire l'objet de changement sans préavis. Consultez le [www.ifar.ca](http://www.ifar.ca) pour voir la plus récente version.

**Support Technique:**  
TEL: 514-255-HELP (4357)  
FAX: 514-255-1367  
Web: [www.ifar.ca](http://www.ifar.ca)