

# Transponder Bypass, Factory Alarm and Door-Lock control for all Chrysler vehicle

## PROGRAMMATION : DATA portion

Once the connections are done.

Connect the connectors 2 and 3, following with connector 1. Turn the key ON, wait a few secondes, the horn or key buzzer will be heard 3 times. Turn the key OFF. The DATA portion of the module is now ready to work.

## PROGRAMMATION : TRANSPONDER portion

The programming procedure of Transponder required 2 functional keys. Keep the keys separate from one another while performing the programming. Each step must be completed within the indicated delay, otherwise the CHRDAА will not program properly.

- 1- Insert the **first functional vehicle key** into the ignition cylinder and turn ignition to the ON position. Maintain ignition in the ON position for **8 to 10 seconds**.
- 2- Turn the key to the OFF position and **remove the first key**.
- 3- **Within 10 seconds** of turning ignition to the OFF position, insert the **second functional key** and **turn ignition to the ON** position. Maintain ignition in the ON position for 8 to 10 seconds.
- 4- Depending on the vehicle model, **the vehicle security light will begin to flash or an audible tone will sound** to indicate you have accessed the vehicle programming mode.
- 5- Turn the key to the OFF position and **remove the second key**.
- 6- Within 10 seconds of turning the key OFF position, **temporarily connect the BLUE wire of CHRDAА module to GROUND AND** following with **12Volts to the ignition** of the vehicle. Approximately 8 to 10 seconds afterwards the security light will stop flashing indicating the CHRDAА has successfully been programmed. Disconnect 12V from ignition.
- 7- **Disconnect the temporary GROUND connection** from the CHRDAА **BLUE wire** and connected the **BLUE wire to the OUT-RUNNING** of remote starter .
- 8- Remotely start the vehicle. The engine will run if the programming procedure was successfully completed. If the programming procedure was unsuccessfully completed, the engine will not run and the vehicle security light flash. In such a case repeat the above procedure beginning with step 1.

\*\* NOTE : Do not attempt to remotely start the vehicle more than 4 consecutive times with a non functional CHRDAА module.

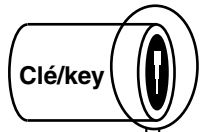

## CHRYSLER DATA ALL

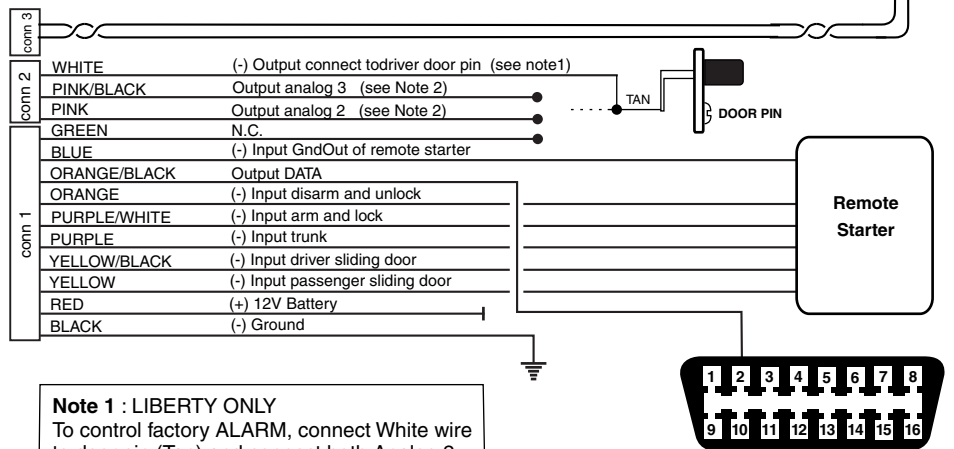
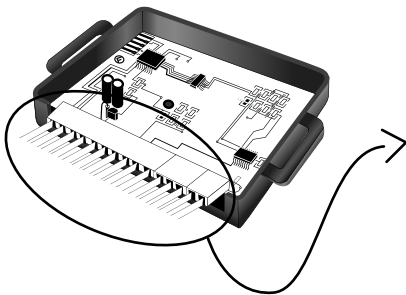

### Note 1 : LIBERTY ONLY

To control factory ALARM, connect White wire to door pin (Tan) and connect both Analog 2 and 3 to vehicle.

Diagnostic plug View from the front  
Located below dash

Note: Neither the manufacturer or distributor of this module is considered to be responsible of damages of any kind indirectly or directly caused by this module, except for the replacement of this module in case of manufacturing defects.

Note 2: Door lock and factory alarm connections, must be connected to the BCM or driver's kick Panel.

## CHRYSLER DATA ALL

Vehicle	Year								Fonctions					Wire Color	
									Transponder Bypass	Door-lock control	Trunk open control	Fartory alarm control	Sliding door control	With OEM Security	Without OEM Security
														Wire : Analog 3	Wire : Analog 2
Cherokee	98	99	00	01	02	03	04	✓	✓		✓		Wire : Analog 3	Wire : Analog 2	
Grand Cherokee		•	•	•	•	•	•	✓	✓		✓		None	None	
Wrangler ( Tj )		•	•	•	•	•	•	✓	✓		✓		None	None	
Liberty	98	99	00	01	02	03	04	✓	✓	✓	✓		Lt. Green/Orange	Pink/Violet	
Dakota					•	•	•	✓	✓		✓		Lt. Green/Orange	White/Green	
Durango			•	•	•	•		✓	✓		✓		Lt. Green/Orange	White/Green	
300m					•	•	•	✓	✓	✓	✓		Lt. Green/Orange	White/Green	
Concorde					•	•	•	✓	✓	✓	✓		Lt. Green/Orange	White/Green	
LHS					•	•	•	✓	✓	✓	✓		Lt. Green/Orange	White/Green	
Intrepid					•	•	•	✓	✓	✓	✓		Lt. Green/Orange	White/Green	
RAM						•		✓	✓		✓		Lt. Green/Orange	White/Green	
RAM 2004							•	✓	✓		✓		Violet / Lt. Blue or Violet / Green		
PT Cruiser					•	•	•	✓	✓	✓	✓		White/Green	White/Green	
Neon					•	•	•	✓	✓	✓	✓		White/Green	White/Green	
Sebring	98	99	00	01	02	03	04	✓	✓	✓	✓		Lt. Green/Orange	White/Green	
Stratus					•	•	•	✓	✓	✓	✓		Lt. Green/Orange	White/Green	
Town & Country	98	99	00	01	02	03	04	✓	✓	✓	✓	✓	Violet/Blue	Violet/Green	
Caravan					•	•	•	✓	✓	✓	✓	✓	Violet/Blue	Violet/Green	
	98	99	00	01	02	03	04								