

GM DATA ALL

All GM data controlled vehicles. Control of doorlock functions, OEM Security, Passlock and PK3 (plus functions as listed below). Interface module self-adjusts to various vehicle platforms (see application chart).

GM DATA ALL

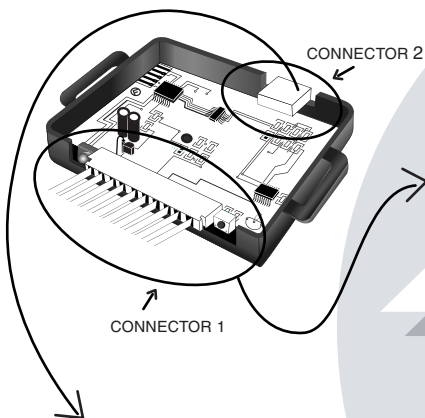

Note: Connector 2 is to be wired only for and Cadillac or if the SECURITY light turned on after start, (see diagrams below).

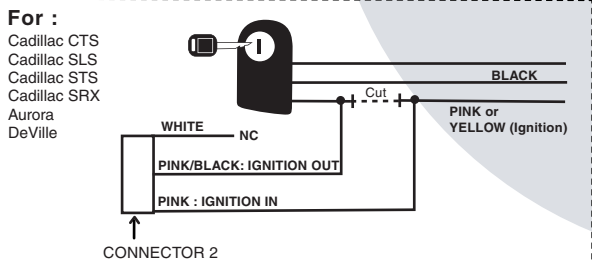

PROGRAMMING SEQUENCE :

- 1 Locate and press the programming switch while inserting the wire harness into connector 1 of the GM DATA ALL module. The LED status indicator will illuminate to indicate you are in programming mode. Keep the programming button pressed while turning the ignition to the "ON" position. Release the programming switch once the LED status indicator flashes rapidly.
- 2 Start the engine (utiling the vehicle key). The LED status indicator will turn off to indicate the module has been programmed for either PK3 or Passlock (and control of additional features where applicable). Turn the key to the "OFF" position. The module is now ready for use.

Note: The manufacturer/distributor is not responsible for any damages which may directly or indirectly result from the installation of this module. The manufacturer/distributor is limited to the repair or replacement of this module in the case of manufacturing defects.

Technical Support:

TEL: 514-255-0446 FAX: 514-255-1367
 Web: <http://support.fortinautoradio.com>

Order Part Number: GMDAA

Version : 3.1
Revision : Dec. 29 2004

Made in Canada

Manufactured under US patent No.:
 5,719,551 6,011,460 B1
 6,243,004 B1 6,249,216 B1
 6,275,147 B1 6,529,124 B2
 6,696,927 B2 6,756,885 B1
 6,756,886 B2 6,771,167 B1
 Canadian patent No.:
 2,320,248 2,415,023
 European patent No.:
 1,053,128

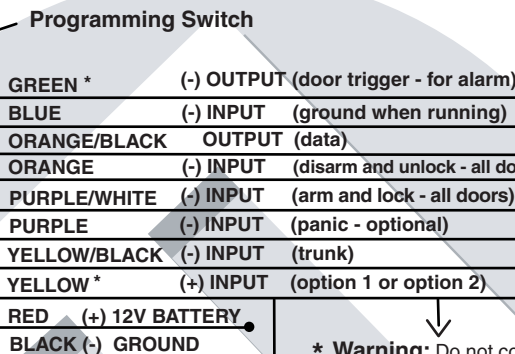

*** Warning:** Do not connect the green or yellow wire (on connector 1) when installing this module in a vehicle equipped with a manual transmission.

Option 1: Positive (+) input (dome light) for use with aftermarket alarm system. Connect to either the vehicle dome light or the under-dash courtesy light.

Option 2: Ignition (+) input for use with select vehicles equipped with PK3. See chart below.

DATA OUTPUT
 PIN # 2 OBDII CONNECTOR

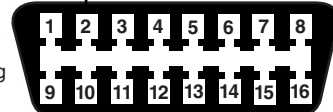

Diagnostic Plug
 View from the front
 Located below dash

Vehicle	Years								PK3 or Passlock Bypass	Doorlock Control	Trunk Release Control	OEM Security Control	Heated Seat Control	Option 1 Dome Light Supervision
	98	99	00	01	02	03	04	05						
Bravada	X	X	X	X
Envoy	X	X	X	X
Trailblazer	X	X	X	X
Rainier
Avalanche	X	X	X	X	X
Escalade	X	X	X	X	X
C/K Pick Up	X	X	X	X	X
Silverado	X	X	X	X	X
Sierra	X	X	X	X	X
Suburban	X	X	X	X	X
Tahoe	X	X	X	X	X
Yukon (all)	X	X	X	X	X
Hummer	X	X	X	X	X
Aurora
Deville	.	?
Allure	.	?
Le Sabre
Bonneville
Park Avenue	.	?	?	?	?	.	.	.
SRX
SLS	.	?
CTS
STS	.	?
ESV
EXT
XLR
Alero
Astro & Safari
Blazer
Cavalier & Sunfire
Express & Savana
Grand Am
Impala & MonteCarlo
Intrigue
Sonoma & S-10
Colorado
Canyon
Saturn Série S
Saturn ION
Saturn VUE
Astek
Grand Prix	NON COMPATIBLE								
Montana
Rendez-vous
Silhouette
Venture
Uplander

GM DATA ALL

Passlock

PK3

Heated Seat will turn ON at low power only if the engine temp is below 0°C when it started.

Option 2: Connect the yellow wire (connector 1) to ignition. This is a mandatory connection for vehicles in this category.

X -- TESTED and functional unique fonction.
 . -- TESTED and functional.
 ? -- Not TESTED on all series of each models, but should be functional.