

INSTALL GUIDE

Covers All 32xx and 33xx Series Remote Starters

REMOTE STARTERS

CAR ALARMS



**ULTRA
START**
GO THE DISTANCE!

WWW.ULTRASTARTERS.COM

Technical Support 866-698-5872 ext 0

Support@ultrastarters.com

Note: Some features may not be available on certain models.

ATTENTION

- The system must be placed into Service Mode before any service work is started on the vehicle. It is the sole responsibility of the vehicle owner to ensure that this is done. The manufacturer accepts no liability or responsibility for accidental starting of the vehicle.
- CARBON MONOXIDE - Never Start in an Enclosed Building (Garage, Carport etc...)
- The Hood Pin Safety Switch Must Always be Installed!
- Never Install Automatic Transmission Remote Starters into a Manual Transmission Vehicle!

Table of Contents

Table of Contents	Page 2
Pre-Installation	Page 3
Components	
Feature List	
Pre-Installation	
Installation Procedures	Page 4
Wiring Diagrams	Page 5-7
Wire Description	Page 8-9
6 Pin Connector	
Auxiliary Connectors	
Optional Connectors	
Jumper Positions	
Quick Start Installation	Page 10
Basic Installation	
Plug-in The Module	
Manual Transmission Vehicles	Page 11
Additional Connections	
Clutch Bypass	
Important Tach Notes	Page 12-13
Auto Tach Learn	
Quick Tach Learn	
Program Overview and Quick View Programming	Page 14-15
Entering Program Mode	
Quick View Programming	
System Reset	
Programming Menus	Page 16-20
Program Menu 1 (User Settings)	
Program Menu 2 (Additional Settings)	
Program Menu 3 (Starter Settings)	
Program Menu 4 (Tach Settings)	
Remote Transmitter	Page 21
1st & 2nd Car Transmitter Programming	
Battery Replacement	
Relay Diagrams	Page 22-23
Door Lock Diagrams	
Diagnostics	Page 24
Diagnostics Chart	
Diagnostic Memory	

Components

- Control module
- Antenna with built in Program Button
- 14 pin harness*
- 3 pin keyless entry harness
- Hood pin safety switch
- 2way LCD remote transmitter
- 6 pin main harness
- 11 pin harness**
- 4 pin harness**
- 2 pin Harness (3350 and LT Models)
- Installation and Owner Manuals

* 32xx series

** 33xx series

Feature List

- Auto Tach learning with Quick Learn option
- Starter Kill/ Anti-Grind Protection
- Remote Panic Feature
- Programmable Wait to Start
- Service Mode (Valet)
- (+/-) Diesel Glow Plug detection
- Run Time 4/ 15 or 45 minutes
- Door Locks .125s/ .75s/3.0s/Double Unlock
- Cold Start With Four Start Intervals or Temp Mode (LT Models Only)
- Turbo Timer Mode
- Engine Idle Mode
- System Override Protection
- Dual Car Operation
- Park Light Diagnostics
- Program 4 Transmitter Codes
- Ignition Auto Lock
- Horn Output (5, 10 or 50ms)

Recommended Pre-Installation Procedures

Remote car starters and alarms should be professionally installed.

Review the installation and owner manuals and acquire a vehicle wiring diagram for the vehicle to be worked on. Take a few moments to walk around the vehicle looking for any damages and make note if any are found. Also check other functions such as vehicle lighting system, warning lights or check engine lights. Check if the vehicle has a factory security or anti-theft. (Transponder or PASS-LOCK system) These systems will require additional parts and labor to complete the installation. Use of the proper tools and testing equipment is also very important. Never use a grounding style test light to test for wires in the vehicle. Use only a Circuit Safe test light or digital Volt/Ohm Meter. It is the sole responsibility of the installer to test and verify all connections

Note: This remote starter system is designed for fuel injected and diesel engines.

If the vehicle is a manual transmission, a “M” series remote starter must be installed. Any model number followed by the letter “M” is specially designed for manual transmission vehicles. The “M” series remote starter will not work in an automatic transmission vehicle.

Recommended Installation Procedures

Proper Connections - Remote Starters can handle loads of up to 30 amps for extended periods of time. It is critical to insure that all high current connections are properly soldered and insulated with quality electrical tape. Failing to insure proper connections will result in warranty being VOID and can result in damage to the vehicle and remote starter module. The manufacturer is not responsible for any such damages. It only takes a few more minutes to do the job right.

Under Hood Connections - Route the hood pin and tach wire through the firewall into the engine compartment. If possible route the wires through a factory rubber grommet. If drilling a hole through the firewall, **BE CAREFUL**. Always check for obstructions on both sides of the firewall. After drilling, use a snap in grommet to protect the wires from sharp edges. Use split loom to insulate the wires, route the wires clear of moving parts and extreme heat. The hood pin switch must always be installed and the tach wire should always be soldered and taped properly.

Installing the External Long Range Antenna -

To insure the best possible reception, place the antenna in the center of the windshield below the tint screen and behind the rear view mirror. Before attaching to the glass ensure that the surface is clean and dry. Run the cable under the head liner and behind the A-pillar panel. Be careful not to pinch the antenna cable. Plug the antenna into the **BLUE** connector on the Control Module.

Mounting The Control Module -

Never mount the module in the engine compartment. Select a location under the dash to install the main module. Be certain that the module is securely attached and does not obstruct any serviceable areas. Do not force or jam the module into tight places instead of mounting. The module must be free from all moving parts such as brake, clutch and gas pedal linkages. Do not place the module directly in front of a heater vent.

Testing The System - When the installation is complete, it will be necessary to test that the system is working correctly. The system's default programming will work on the majority of vehicles, but might need to be adjusted for some applications. If the installation requires special timing or additional features, proceed to Program Mode. The system must be Tach Learned (Tachless learned on Tachless models) before the remote starter will make a start attempt. If the remote starter does not make a start attempt check if the park lights are flashing a diagnostic code, if so look the code up in the Diagnostic Chart to find the shutdown input that is preventing the system from starting. If the vehicle does make a start attempt but fails to start. Check all connections and insure that all wiring is connected correctly. The vehicle may be equipped with a factory anti-theft system. Vehicles equipped with factory anti-theft systems will usually have some sort of *Security* or *Anti-Theft* light located in the instrument cluster.

Wiring Diagram - 11 pin + 4 pin Connectors

30amp Output	Starter Output	YELLOW	
30amp Output	Heater/Acc Output	GREEN	
30amp Input	Power Input	RED	
30amp Input	Power Input	RED	
30amp Output	Selectable Output	WHITE	
30amp Output	Ignition Output	BLUE	
(-)250ma Output	Factory Re-arm Output	YELLOW	
(-)250ma Output	Trunk Release Output	RED/WHITE	
(-)250ma Output	Factory Disarm Output	BROWN	
(-)250ma Output	Starter kill & Anti-Grind Output	ORANGE	
(-)250ma Output	(-) Horn Honk Output	WHITE/BLUE	
Negative Input	Negative Park Brake Input	BLACK/WHITE*	
Positive Input	Positive Door Pin Input	PURPLE*	
Positive Output	(+)10amp Park Light Output	WHITE	
Negative Input	Hood Pin Switch Input	GREEN/WHITE	
Negative Input	Negative Door Pin Input	GREEN*	
Negative Input	System Ground Input	BLACK	
Negative Output	(-)When Running Output	White/Violet	
(+ or -) Input	Diesel Glow Plug Input	BLUE	
A/C Input	Tach Detection Input	BLUE/WHITE	
Positive Input	Brake Switch Input	PINK	

*** These connections are for manual transmission vehicles only!**

"M" models must always be installed into manual transmission vehicles.

Manual transmission "M" modules are cased in Yellow plastics.

Note: 250ma outputs are low current and may require the installation of a relay for the activation of optional features.

Wiring Diagram 14 pin connector

30amp Output	Starter Output	YELLOW
30amp Output	Heater/Acc Output	GREEN
30amp Input	Power Input	RED
30amp Input	Power Input	RED
30amp Output	Selectable Output	WHITE
30amp Output	Ignition Output	BLUE
(-)250ma Output	Factory Re-arm Output	YELLOW
(-)250ma Output	Trunk Release Output	RED/WHITE
(-)250ma Output	Factory Disarm Output	BROWN
(-)250ma Output	Starter kill & Anti-Grind Output	ORANGE
(-)250ma Output	(-) Horn Honk Output	WHITE/BLUE
Negative Input	Negative Park Brake Input	BLACK/WHITE*
Positive Input	Positive Door Pin Input	PURPLE*
Positive Output	(+)10amp Park Light Output	WHITE
Negative Input	Hood Pin Switch Input	GREEN/WHITE
Negative Input	Negative Door Pin Input	GREEN*
Negative Input	System Ground Input	BLACK
Positive Input	Brake Switch Input	PINK
A/C Input	Tach Detection Input	BLUE/WHITE
(+ or -) Input	Diesel Glow Plug Input	BLUE

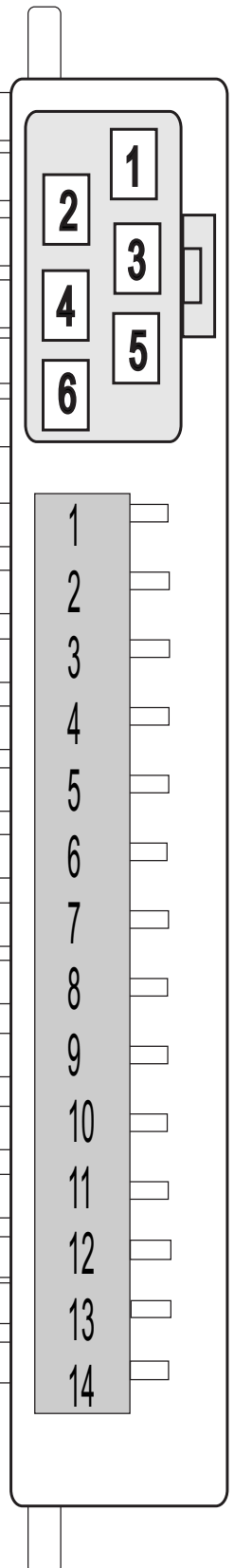

*** These connections are for manual transmission vehicles only!**

“M” models must always be installed into manual transmission vehicles.

Manual transmission “M” modules are cased in Yellow plastics.

Note: 250ma outputs are low current and may require the installation of a relay for the activation of optional features.

Wiring Diagram auxiliary connectors

* The centre pin of the keyless entry harness is not to be used for anything besides plug-in devices such as the VP-1, DL-3, DL-7 and Data Bus Modules. Overloading this output will damage the remote starter.

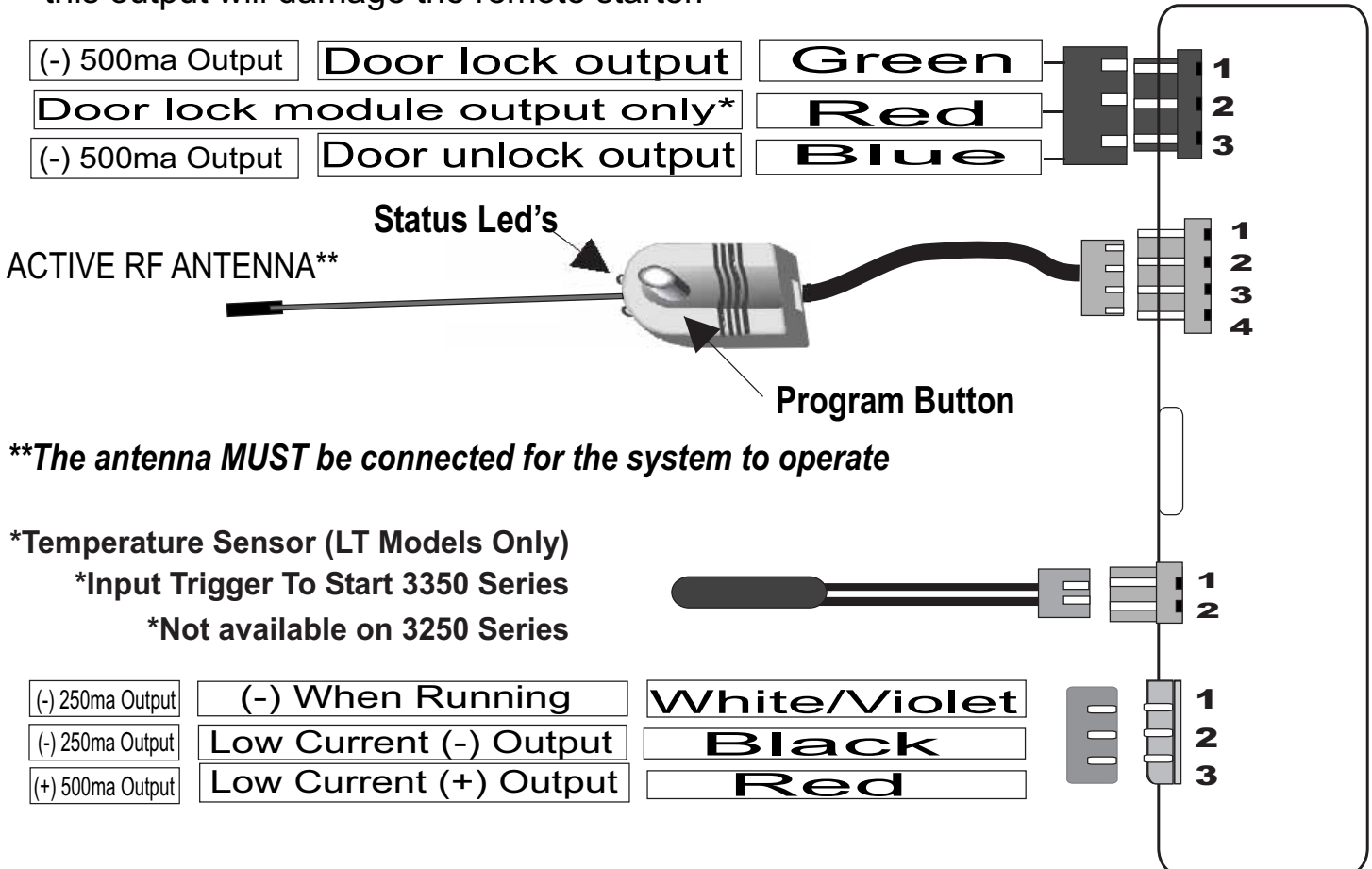

The antenna **MUST be connected for the system to operate

*Temperature Sensor (LT Models Only)

*Input Trigger To Start 3350 Series

*Not available on 3250 Series

(-) 250ma Output	(-) When Running	White/Violet
(-) 250ma Output	Low Current (-) Output	Black
(+) 500ma Output	Low Current (+) Output	Red

Output on White wire	Jumper position
Second Starter	Position 1
Second Accessory	Position 2
Second Ignition	Position 3

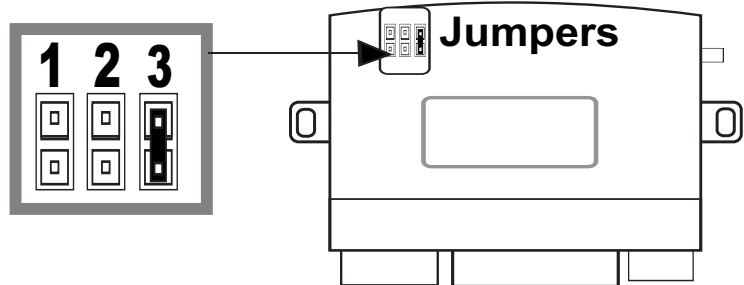

The jumpers control the output from the **WHITE** wire on the 6- pin harness. This is an **30amp relayed output**. Place the jumpers in the following order to change the output.

If the jumper is in position #1 the output on the white wire will be **2nd Starter**

If the jumper is in position #2 the output on the white wire will be **2nd Accessory**

If the jumper is in position #3 the output on the white wire will be **2nd Ignition**

*The factory default setting of the selectable output jumper is position #3.

6 Pin Power Connector

6-pin	Description	Test For Wire
1-Yellow	30amp Starter Output -	<i>This wire will test 0volts in off, accessory and in the ignition position. 12volts during start only.</i>
2-Green	30amp Heat/Acc Output -	<i>This wire will test 0volts in the off position 12-14volts in the accessory and run positions and 0 volts during start</i>
3-Red	30amp Power Input -	<i>12volts at ignition harness or from battery. Supplies power for the ignition, selectable output and park light relays.</i>
4-Red	30amp Power Input -	<i>12volt power at ignition harness or from battery. Supplies power for accessory and start relays</i>
5-Blue	30amp Ignition Output -	<i>This wire will test 0volts in the off and accessory position 12volts in the ignition, start and run.</i>
6-White	30amp Select Output -	<i>Selectable output for 2nd Ign, acc or starter.</i>

Auxiliary Connectors - 4, 11 and 14 pin Connectors

Pin Number	Function	Description
1-Yellow	Re-Arm Output -	<i>0.75 second pulsed output when locked and on remote start shutdown. Used for factory alarm re-arm. Programmable output. See Menu 3</i>
2-Red/Wht	Trunk Release Output (-) -	<i>Hold the unlock button for 3 seconds. Output will stay on until the unlock button is released (Max 5 seconds) Programmable to (-)Park lights. See Menu 2</i>
3-Brown	Disarm Output (-) -	<i>0.75sec pulsed output when unlocked and pulse before remote start activation. Used for Factory Alarm Disarm.</i>
4-Orange	Starter Kill and Negative While Run Output (-) -	<i>Active when locked and/or during remote start. Anti-Grind - Used for optional starter disable, and anti-grind relay. Programmable output. See Menu 3</i>
5-White/Blue	Horn Output (-) -	<i>Output to activate factory horn. Programmable output See Menu 1&2</i>
6-Black/White	Park Brake Input (-) -	<i>Input to detect Park Brake Switch. Connect switch that provides (-) when the switch is applied.</i>
7-Purple	Door Pin Input (+) -	<i>Input to detect door opening. Connect to door pin that switches to 12volts when the door opened.</i>
8-White	Park Lights Output (+) -	<i>+10amp park light output. Connect At light harness 0volts when Parking Lights are off, 12volts when park lights are on.</i>
9-Green/White	Hood Pin Input (-) -	<i>Negative input from hood pin safety switch. Switch is grounded when the hood is opened. Must be connected.</i>
10-Green	Door Pin Input (-) -	<i>Input to detect door opening. Connect to door pin that switches to Negative when the door is opened.</i>

Auxiliary Connectors - continued from previous page

- 11-Black** Ground - System Chassis Ground Input.
- 12-Blue** Glow Plug - Diesel Glow plug input, detects both 12volt and negative glow plug signals. Programmable input. See Menu 3.
- 13-Blue/White** Tach - A/C Tach Signal Input. Used to detect when the vehicle has started. This wire is connected to the vehicles coil, fuel injector or crank sensor wire.
- 14-Pink** Brake input - Positive Brake Input. Used to detect the brake switch being Applied. Found at the brake switch connector.
- 15-Wht/Violet** GWR - (-) Output while remote starter is activated. Used to activate Anti-theft bypass modules, adding 3rd ign etc.

3 Pin Connector Red

- 1-Green** Door Lock - Door Lock Output - Programmable Menu 1 Setting 3.
- 2-Red** 12volt Output - *Output For Door Lock Module Only!
- 3-Blue** Door Unlock - Door Unlock Output - Programmable Menu 1 Setting 3.

** The centre pin of the keyless entry harness is not to be used for anything besides plug-in devices such as the VP-1, DL-3, DL-7 and Data Bus Modules.
Overloading this output will damage the remote starter.*

4 Pin Connector Blue

RF Antenna/ Program Button Connector.

Remove the plastic from the adhesive tape and place the antenna in the center of the windshield, behind the rear view mirror. Run the cable behind the head liner and A-pillar panels to the module under the dash.

*****The Antenna Must Be Connected Before the System will Operate.*****

2 Pin Connector White

Connector for Instant Start Input or Temperature Sensor on LT models.

Note: *This Input is not available on the 3250 Series.*

3 Pin Connector White

- 1- White/Violet GWR** - Ground output while running. This output can be used for bypass module activation or adding additional relays.
- 2- Black Ground** - Low current constant ground output.
- 3- Red- 12volts** - Low current constant 12volt output.

Step 1 - Connect All Of the Following Wires

6 Pin Power Connector

Yellow	30amp Starter Output - 12volts during start position only.
Green	30amp Heater Output - 12volts in the accessory position off during start and 12volts during run.
Red	30amp Power Input - Constant 12volt power at ignition harness or from battery.
Red	30amp Power Input - Constant 12volt power at ignition harness or from battery.
Blue	30amp Ignition Output - 12volts in the ignition, start and when run positions.
White	30amp Select Output* - Selectable Output for vehicles that require 2n Ign, Acc or Starter wires. See jumper diagram.

Note: The white wire may not be required on all vehicles.

Auxiliary Connectors

Black	System Ground Input - Connect to Chassis Ground.
White	Park Light Output - Connect to (+) Park Light system.
Green/Wht	Hood Pin Input - Connect to the Hood Pin Safety Switch.
Blue/White	Tach - Connect To A/C Tach Source. (Above 2volts AC)
Pink	Brake Switch - Connect To (+) When Brakes Is Applied.

Manual Transmission Connections ("M" Models Only)

Black/Wht	Park Brake Input - Connect to Park Brake wire.
Green*	(-) Door Pin Input - Connect to door pin (-) when doors opened.
Purple*	(+) Door Pin Input - Connect to door pin (+) when doors opened.

Note: Connect only one of the door pin inputs. If the vehicle has a positive door pin system connect the purple wire, if negative connect the green wire.

Never install an automatic module into a manual transmission vehicle!

Step 2- Plug-In The Module

When all the connections are done, the control module can be plugged in. Before connecting the control module, make sure the ignition is in the **OFF** position. Plug in the 6 pin harness and the Auxiliary harness, then any other connectors that were used. The park lights will flash and the horn will honk 2 times to confirm power up on automatic transmission models. Manual transmission models will flash the park lights and honk the horn 4 times to confirm power up.

Manual Transmission “M” Models

Never install an automatic transmission remote starter into a manual transmission vehicle!!! Doing so may result in serious injury or death. Do not install remote starters in convertible vehicles! The following wires must be connected In addition to the basic remote starter installation.

Park Brake Input- This wire is located at the park brake switch. The wire will switch to (-) when the park brake is applied. Never connect the Black/White wire straight to a ground!!!

(-) Door Pin Input- A negative door pin wire will be (+) or neutral when the door is closed then switch to (-) when the door is opened. Always ensure that **all** the vehicles doors are sensed by this wire.

(+) Door Pin Input- A positive door pin wire will be (-) or neutral when the door is closed then switch to (+) when the door is opened. Always ensure that **all** the vehicles doors are sensed by this wire.

***If any Door Pin Switches or the Park Brake Switch is not working correctly...

“DO NOT INSTALL UNTIL THE VEHICLE IS REPAIRED!!!”***

Clutch Bypass - In most cases the clutch switch will need to be bypassed during remote Starting. This is a temporary bypass, the clutch switch should never be disconnected or altered to not work as it is intended to “As a Safety Switch”. The clutch switch is usually a 2 wire switch mounted directly to the clutch pedal. There are several types of clutch switches that operate in one of the following ways.

Type 1 - Starter Wire Bypass - The starter wire travels from the key switch through the clutch switch to the starter motor. Connect the Remote Starters Starter Output wire directly to the starter motor side of the clutch switch.

Type 2 - Negative (High Current) This switch grounds the factory starter relay and allows the vehicle to start. Connect a relay to ground the clutch switch wire when the remote starter is activated. The starter wire is connected at the ignition switch.

Type 3 - Connect Switch Install a relay to connect the two wires at the switch when the remote starter is activated. The starter wire is connected at the ignition switch.

Type 4 - Disconnect Switch Install a relay to disconnect one of the wires at the clutch switch. The starter wire is connected at the ignition switch.

Testing for the correct wire is critical! Never connect to a circuit if you are not sure of its operation. Contact your dealer or technical support for more information.

Auto Tach Learn

- 1) Turn the ignition key to the "ON" position. (The park lights will turn on*).
- 2) Start the vehicle with the key, The LEDs on the antenna will turn on if a proper tach signal is detected**, then after 30-35 seconds the park lights will flash and the horn (Optional) will honk twice to confirm Tach Learn.

* If the park lights do not turn on check for proper connection on the BLUE ignition wire at the 6-pin connector. This wire should be connected to the vehicle main ignition wire and must not turn off during the start position. If the ignition connection is good reset the system and repeat step #1.

** If the LEDs do not come on during tach learn, a proper tach signal was not detected.

If not tach learned the system will flash the park lights seven times when the start button is pressed. The system must be Tach Learned before remote starting.

Note: If the park lights do not flash in auto tach learn mode it may be necessary to connect to a different tach source. It is important the ignition output from the remote starter is connected to a wire that does not turn off in the crank position. The remote starter will not tach learn if connected to the wrong wire.
For best results connect the tach wire to the coil pack or to a fuel injector wire.

New - If the original Tach source is changed a system reset must be preformed before a new tach signal can be learned to the system. This does not apply if the Quick Learn feature is being used. See page 15 for system reset.

Your Basic Install Is Complete!

NOTES:

- 1) If the vehicle does not start when the remote starter is activated, check if the park lights are flashing a diagnostic code. See diagnostic chart.
- 2) If the vehicle still does not start, check all connections and check for factory Anti-Theft system.

Note: If the vehicle is not starting correctly it may be necessary to adjust the tach. See page 13 for Quick Tach Learn.

Important Tach Notes

Tach Learning the remote starter is one of the most important steps in the installation process. Do not tach learn vehicle while the engine is in high idle. To ensure the best possible tach setting, ensure that the vehicle is at low idle/ normal operating RPM. Vehicles such as Toyota and Honda may idle much higher when the engine is warm compared to starting the vehicle when the engine is cold. The Quick Learn feature may be used to tach learn the vehicle again but at a normal engine RPM.

Quick learn Tach

Start the vehicle with the key.

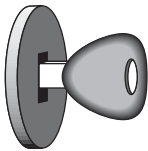

Hold the brake pedal.



Press and release the program button, then press and hold.



Quick Learn Tach is designed to re-learn the remote starters tach setting while the vehicle is at normal idle RPM. Vehicles such as Toyota and Honda will run at a very high idle for a number of minutes when first started. If tach learned when the vehicle is at high Idle, then remote started when the vehicle is cold. The engine does not increase to the RPM that is was learned at.

The Following steps can be used to learn tach at a more suitable idle:

- 1) Start the vehicle and leave running by the ignition key until the engine idles down.
- 2) Press and hold the brake pedal.
- 3) Press and release the Program Button (Located on the antenna) then press and hold.
- 4) The park lights will flash to confirm Quick Learn Tach*.

Note: The remote starter must be Tach Learned before the Quick Tach Learn feature will operate.

TIP- “Manual Low Idle Learn”. While in the tach learning mode firmly apply the park brake then hold the brake pedal. Place the transmission into reverse gear and wait for the park lights to flash confirming Tach Learn.

Entering Program Mode

- 1) With the ignition in the OFF position, turn the ignition key from “Off” to “On” 3 times, ON-OFF-ON-OFF-ON within three seconds. (Leave the key in the ON position)
- 2) Press and release the Program Button located on the antenna. The park lights will flash and the horn (optional) will honk to confirm entering program mode.
- 3) Select desired Program Menu (See below). The park lights will flash and horn (optional) will honk to confirm the selected menu.
- 4) Select Programmable Setting:
 - a) *Press and release* the Program Button the correct number of times to select the desired Program Setting. The park lights and LEDs will flash and the horn (optional) will honk to indicate the Program Setting that has been selected. *For example:* 1 flash/honk= Program Setting 1; 2 flashes/honks= Program Setting 2; etc...
 - b) *Press and Hold* the Program Button until the park lights flash and the horn(optional) honks to confirm the desired setting. *For example:* 1 flash/honk= Setting 1; 2 flashes/honks= Setting 2; 3 flashes/honks= Setting 3.
 - c) Turning the ignition key to the “Off” position or 30 seconds of no activity will exit Program Mode. This will be confirmed with a light flash and a long horn (optional) honk. The Program Menu may be changed at any time by pressing the transmitter button (below), this will allow the installer to jump from one menu, then quickly jump to another menu and change another setting without re-entering Program Mode.

Note: If unit does not enter Program mode, turn ignition off for 5 seconds and repeat steps 1-4.

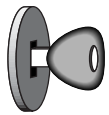

Ignition 3x
On/Off
On/Off On



Press and
Release



Press button
1 for Menu 1



Press button
2 for Menu 2



Press button
3 for Menu 3

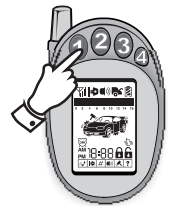

Press button
4 for Menu 4

Program Menus

Menu 1: User Settings (Button #1)

This program menu is for the adjustments for the user and door lock options.

Page 16

Menu 2: Additional Settings (Button #2)

This program menu is for additional settings.

Page 17

Menu 3: Starter Settings (Button #3)

This program menu is for various remote car starter applications.

Page 18-19

Menu 4: Tach Settings (Button #4)

This program menu is for tach signal adjustments.

Page 20

Quick View Programming

* See the following pages for more detailed programming instructions.

Menu 1 - Press Lock	1 Flash	2 Flashes	3 Flashes
1 Ignition Lock	Enabled	Lock Only	Disabled
2 Horn Honk	Type 1	Type 2	All Honks
3 Lock&Unlock Options	Double Unlock	3 second	.75 second
4 Unlock/Disarm	125ms	750ms	
Menu 2 -Press Unlock	1 Flash	2 Flashes	3 Flashes
1 Secure Service Mode	15 seconds	5 seconds	
2 Park Light Output	30 seconds	(-) Park Light	Light Flash
3 Horn Timing	5ms	50ms	10ms
4 Button #4 Programmable	Trunk Release	Garage Door	Car Finder
5 Reservation Mode	Manual	Auto Reservation	
Menu 3 -Press Start	1 Flash	2 Flashes	3 Flashes
1 Lock/ Unlock Type	Type 1	Type 2	Normal
2 Gas/ Diesel	Negative	15 second	Gas/ Positive
3 Rearm Output	Type 1	Type 2	Rearm
4 Run Time	4 Min	45 Min	15 Min
5 Crank Time	10 seconds	3 seconds	5 seconds
6 Starter Disable/GWR	Active	Passive	GWR
7 Safety Start Mode	Press twice	Press once	
Menu 4 -Press #	1 Flash	2 Flashes	3 Flashes
1 Low Idle Learn	Low Idle Learn		
2 Adjust For Over Crank	Reduced by 10%		
3 Adjust For under Crank	Increased by 10%		

****Bold type indicates settings that are Factory Default.**

System Reset

The system reset will clear any changes made to the Program Menu's as well as the Tach setting. When the system reset is complete the system must be Tach learned before the remote starter will operate.

- 1) Turn the ignition key from "Off" to "On" 3 times, **ON-OFF-ON-OFF-ON** within three seconds. (Leave the key in the **ON** position)
- 2) Press and release the **Program Button** located on the antenna. The park lights will turn on and the horn (optional) will honk one time.
- 3) Then press and hold the **Program Button** until the park lights flash and the horn (optional) will honk 3 times slowly to confirm system reset.

System is now reset to factory defaults.

Note: System Reset does not delete the transmitter codes from memory.

Menu 1- User Settings



Ignition 3x
On/Off
On/Off On



Press and
Release the
Program
Button



Press button
1 to enter
Program Menu 1



Press and
Release the
Program Switch
1x =Setting 1
2x =Setting 2
3x =Setting 3....



Press and
Hold the
Program Switch
1x = Option 1
2x = Option 2
3x = Option 3....

Ignition **ON-OFF-ON-OFF-ON**

Press & Release **Program Button**

Press **Button #1**

Setting 1 Ignition Auto Lock

- | | | |
|---|------------------------|--|
| 1) Ignition Lock & Unlock Enable | 1 Flash/Honk | Doors Lock/Unlock with Ignition key. |
| 2) Ignition Lock Only | 2 Flashes/Honks | Doors Lock when ignition is turned ON only. |
| *3) Ignition Auto Lock Disable | 3 Flashes/Honks | Doors do not Lock/Unlock with Ignition key. |

Press & Release the Program Button 1 Time (Setting 1) Confirmed with 1 LED flash.

Press & Hold the Program Button until the appropriate # of park lights/horn (optional) honks, then release.

Press & Release the Program Button to proceed to the next step.

Setting 2 Horn Honk Settings (Auxiliary Connector Pin 5)

- | | | |
|--|------------------------|--|
| 1) Lock & Unlock chirps Disable | 1 Flash/Honk | Honks for Panic/Car Finder Only . |
| 2) Lock & Unlock chirps Enable | 2 Flashes/Honks | Honks for Lock/Unlock/Panic/Car Finder Only |
| *3) All Chirps Enable | 3 Flashes/Honks | Honks for all features. |

Press & Release the Program Button 2 Times (Setting 2) Confirmed with 2 LED flashes.

Press & Hold the Program Button until the appropriate # of park lights/horn (optional) honks, then release.

Press & Release the Program Button to proceed to the next step.

Setting 3 Door Lock Options

- | | | |
|--------------------------------------|------------------------|--|
| 1) Double Unlock Pulse | 1 Flash/Honk | .75 Second lock & 2 unlock pulses |
| 2) 3 Second Lock & Unlock | 2 Flashes/Honks | 3 Second Lock & Unlock Pulses |
| *3) .75 Sec Lock & Unlock | 3 Flashes/Honks | .75 Second Lock & Unlock Pulses |

Press & Release the Program Button 3 Times (Setting 3) Confirmed with 3 LED flashes.

Press & Hold the Program Button until the appropriate # of park lights/horn (optional) honks, then release.

Press & Release the Program Button to proceed to the next step.

Setting 4 Door Unlock & Disarm Pulse Duration

- | | | |
|--------------------------|------------------------|---|
| 1) Short Pulses | 1 Flash/Honk | 125ms pulses on Unlock & Disarm outputs |
| *2) Normal Pulses | 2 Flashes/Honks | 750ms pulses on Lock/Unlock & Disarm outputs |

Press & Release the Program Button 4 Times (Setting 4) Confirmed with 4 LED flashes.

Press & Hold the Program Button until the appropriate # of park lights/horn (optional) honks, then release.

Press & Release the Program Button to proceed to the next step.

***Settings 5, 6 and 7 are not available.**

Menu 2- Additional Settings

Ignition **ON-OFF-ON-OFF-ON**
 Press & Release Program Button
 Press Button #2



Ignition 3x
 On/Off
 On/Off On



Press and
 Release the
 Program
 Button



Press button
 2 to enter
 Program
 Menu 2



Press and
 Release the
 Program Switch
 1x =Setting 1
 2x =Setting 2
 3x =Setting 3....



Press and
 Hold the
 Program Switch
 1x = Option 1
 2x = Option 2
 3x = Option 3....

Setting 1 Secure Valet Mode - Length of time required to set the system into Service Mode

- | | | |
|------------------|-----------------|--|
| 1) Secure Valet | 1 Flash/Honk | Hold the Program Button for 15 seconds |
| *2) Normal Valet | 2 Flashes/Honks | Hold the Program Button for 5 seconds |

Press & Release the Program Button 1 Time (Setting 1) confirmed 1 LED flashes.

Press & Hold the Program Button until the appropriate # of park light/horn (optional)honks, then release.

Press & Release the Program Button to proceed to the next step.

Setting 2 Parking Light/Trunk Output (14 pin auxiliary connector pins 2&8)

- | | | |
|-------------------------|-----------------|--|
| 1) 30 sec. Output | 1 Flash/Honk | Park Lights on for 30 seconds when Unlock is pressed |
| 2) Negative Park Lights | 2 Flashes/Honks | Switches the Park Lights/Trunk Outputs |
| *3) Park Lights | 3 Flashes/Honks | Park light flash as confirmation of feature activation. |

Press & Release the Program Button 2 Times (Setting 2) confirmed 2 LED flashes.

Press & Hold the Program Button until the appropriate # of park light/horn (optional)honks, then release.

Press & Release the Program Button to proceed to the next step.

Setting 3 Horn Honk Timing (14 pin auxiliary connector pin 5)

- | | | |
|------------------------|-----------------|--|
| 1) 5 ms Pulse Output | 1 Flash/Honk | Short(Quiet) Horn Output Pulses |
| 2) 15 ms Pulse Output | 2 Flashes/Honks | Long(Loud) Horn Output Pulses |
| *3) 10 ms Pulse Output | 3 Flashes/Honks | Normal(Medium) Horn Output Pulses |

Press & Release the Program Button 3 Times (Setting 3) confirmed 3 LED flashes.

Press & Hold the Program Button until the appropriate # of park light/horn (optional)honks, then release.

Press & Release the Program Button to proceed to the next step.

Setting 4 Button #4 Programmable

- | | | |
|------------------|-----------------|---|
| 1) Trunk Release | 1 Flash/Honk | Holding button #4 will activate Trunk Release |
| 2) Garage Door | 2 Flashes/Honks | Activates optional Garage Door Interface |
| 3) Car Finder | 3 Flashes/Honks | Holding Button #4 activates Car Finder |

Press & Release the Program Button 4 Times (Setting 4) confirmed 4 LED flashes.

Press & Hold the Program Button until the appropriate # of park light/horn (optional)honks, then release.

Press & Release the Program Button to proceed to the next step

Setting 5 Reservation Mode ("M" units only)

- | | | |
|-----------------------|-----------------|--|
| 1) Manual Reservation | 1 Flash/Honk | Activate Reservation Mode by pressing Button #4 |
| *2) Auto Reservation | 2 Flashes/Honks | Activate Reservation Mode by pressing brake |

Press & Release the Program Button 5 Times (Setting 5) confirmed 5 LED flashes.

Press & Hold the Program Button until the appropriate # of park light/horn (optional)honks, then release.

Press & Release the Program Button to proceed to the next step.

Menu 3- Starter Settings

Ignition **ON-OFF-ON-OFF-ON**
Press & Release **Program Button**
Press **Button#3**



Ignition 3x
On/Off
On/Off On



Press and
Release the
Program
Button



Press button
3 to enter
Program
Menu 3



Press and
Release the
Program Switch
1x =Setting 1
2x =Setting 2
3x =Setting 3....



Press and
Hold the
Program Switch
1x = Option 1
2x = Option 2
3x = Option 3....

Setting 1 Special Door Lock/Unlock Operations (Factory Alarm Rearm).

- | | | |
|------------|-----------------|--|
| 1) Type 1 | 1 Flash/Honk | Unlock pulse before start. Lock pulse after start and on shutdown. |
| 2) Type 2 | 2 Flashes/Honks | Lock pulse ONLY after remote start shutdown. |
| *3) Type 3 | 3 Flashes/Honks | Default Lock/ Unlock Pulses. |

Press & Release the Program Button 1 Time (Setting 1) Confirmed with 1 LED flashes.

Press & Hold the Program Button until the appropriate # of park lights/horn (optional) honks, then release.

Press & Release the Program Button to proceed to the next step.

Setting 2 With 11 pin Connector- Gas/Diesel Mode (Auxiliary Connector Pin 12)

- | | | |
|--------------------|-----------------|---|
| 1) (+) Input | 1 Flash/Honk | (+) Glow Plug input. Waits maximum 30 seconds then starts. |
| 2) Time Delay | 2 Flashes/Honks | Waits for approximately 15 seconds then remote starts. |
| *3) Gas/ (-) Input | 3 Flashes/Honks | Waits 2 seconds to start if no diesel input is detected. |

Press & Release the Program Button 2 Times (Setting 2) Confirmed with 2 LED flashes.

Press & Hold the Program Button until the appropriate # of park lights/horn (optional) honks, then release.

Press & Release the Program Button to proceed to the next step.

Setting 2 With 14pin Connector- Gas/Diesel Mode (Auxiliary Connector Pin 12)

- | | | |
|--------------------|-----------------|---|
| 1) (-) Input | 1 Flash/Honk | (-) Glow Plug input. Waits maximum 30 seconds then starts. |
| 2) Time Delay | 2 Flashes/Honks | Waits for approximately 15 seconds then remote starts. |
| *3) Gas/ (+) Input | 3 Flashes/Honks | Waits 2 seconds to start if no diesel input is detected. |

Press & Release the Program Button 2 Times (Setting 2) Confirmed with 2 LED flashes.

Press & Hold the Program Button until the appropriate # of park lights/horn (optional) honks, then release.

Press & Release the Program Button to proceed to the next step.

Note: Setting 2 will vary depending on the board layout 11 or 14 pin connectors.

Setting 3 Rearm Output (Auxiliary Connector Pin 1)

- | | | |
|--------------------|-----------------|--|
| 1) Type 1 | 1 Flash/Honk | Pulse after start and with lock. (Provides Lock Pulse) |
| 2) Type 2 | 2 Flashes/Honks | Pulse after start only. (Provides Lock Pulse) |
| *3) Factory Re-arm | 3 Flashes/Honks | Pulse with lock and after starter shutdown. |

Press & Release the Program Button 3 Times (Setting 3) Confirmed with 3 LED flashes.

Press & Hold the Program Button until the appropriate # of park lights/horn (optional) honks, then release.

Press & Release the Program Button to proceed to the next step.

Menu 3- Starter Settings - Continued From Previous Page

Setting 4 Run Time

- | | | |
|-----------------------|------------------------|--|
| 1) 4 Minutes | 1 Flash/Honk | Runs for approximately 4 minutes when activated. |
| 2) 45 Minutes | 2 Flashes/Honks | Runs for approximately 45 minutes when activated. |
| *3) 15 Minutes | 3 Flashes/Honks | Runs for approximately 15 minutes when activated. |

Press & Release the Program Button 4 Times (Setting 4) Confirmed with 4 LED flashes.

Press & Hold the Program Button until the appropriate # of park lights/horn (optional) honks, then release.

Press & Release the Program Button to proceed to the next step.

Setting 5 Maximum Crank Time

- | | | |
|----------------------|------------------------|---|
| 1) 10 Seconds | 1 Flash/Honk | 10 sec max time that the starter will stay engaged. |
| 2) 3 Seconds | 2 Flashes/Honks | 3 sec max time that the starter will stay engaged. |
| *3) 5 Seconds | 3 Flashes/Honks | 5 sec max time that the starter will stay engaged. |

Press & Release the Program Button 5 Times (Setting 5) Confirmed with 5 LED flashes.

Press & Hold the Program Button until the appropriate # of park lights/horn (optional) honks, then release.

Press & Release the Program Button to proceed to the next step.

Setting 6 Anti-Grind/Starter Kill (Auxiliary Connector Pin 4)

- | | | |
|-----------------------|------------------------|--|
| 1) Active | 1 Flash/Honk | (-) when locked and during remote start (Anti-Grind). |
| 2) Passive | 2 Flashes/Honks | (-) when locked /30 seconds after ignition is Off or unlock is pressed |
| *3) Anti-grind | 3 Flashes/Honks | Output during remote start only. (Anti-grind/ Bypass module) |

Press & Release the Program Button 6 Times (Setting 6) Confirmed with 6 LED flashes.

Press & Hold the Program Button until the appropriate # of park lights/horn (optional) honks, then release.

Press & Release the Program Button to proceed to the next step.

Setting 7 Safety Start

- | | | |
|-----------------------|------------------------|---|
| 1) Safety On | 1 Flash/Honk | Press the start button twice within 3seconds to remote start vehicle. |
| *2) Safety Off | 2 Flashes/Honks | Press the start button once to remote start vehicle. |

Press & Release the Program Button 7 Times (Setting 7) Confirmed with 7 LED flashes.

Press & Hold the Program Button until the appropriate # of park lights/horn (optional) honks, then release.

Press & Release the Program Button to proceed to the next step.

Menu 4- Tach Settings

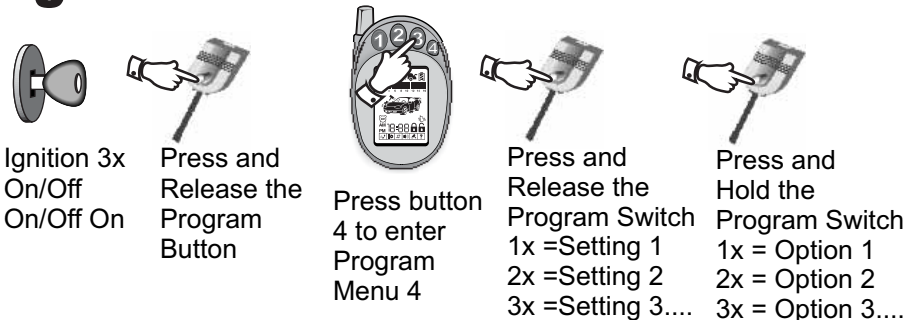

Setting 1 Auto Tach Learn.

- 1) Perform a System Reset. **See page 15.**
- 2) Turn the ignition key on. (Park lights will turn on).
- 3) Start the vehicle, the LEDs on the antenna will come on when a proper tach signal is detected*.
- 4) After approximately 30-35 seconds the park lights will go out then will flash twice and the horn (optional) will honk twice to confirm that a tach signal has been learned.

****If the LEDs do not come on, a proper signal is not detected. Try a different tach source and follow steps 1 thru 4.***

Setting 2 Over-Crank Adjustment.**

- 1) Enter Program Mode (turn ignition ON-OFF-ON-OFF-ON), press and release the Program Button.
- 2) Press and release the # button on the remote.
- 3) Press and release the Program Button twice. (LEDs will flash 2 times consecutively)
- 4) Press and hold the Program Button. The park lights flash and the horn will honk one time.
*Each time the park lights flash and the horn honks the setting is reduced.
- 5) Release the Program Button. (Exit Program Mode and test remote starter)

Setting 3 Under-Crank Adjustment.**

- 1) Enter Program Mode (turn ignition ON-OFF-ON-OFF-ON), press and release the Program Button.
- 2) Press and release the # button on the remote.
- 3) Press and release the Program Button three times. (LEDs will flash 3 times consecutively)
- 4) Press and hold the Program Button. The park lights will flash and the horn will honk one time.
*each time the park lights flash and the horn honks the setting is increased.
- 5) Release the Program Button. (Exit Program Mode and test remote starter)

*****Repeat steps 1-5 if necessary.***

Transmitter Programming

Step 1 - Within 3 seconds turn the ignition **ON-OFF-ON-OFF-ON** - Leaving Key ON

Step 2 - Press and hold the Program Button - The park lights will turn ON and the siren will chirp once.*

Continue to hold the Program Button, the park lights will turn off and the siren will chirp 5 times quickly.

Step 3 - While holding the Program Button, press the **LOCK** button on each of the remote's to be programmed.

If remote's are being programmed for 2nd Car Operation press the # button on each of the **2nd car** remote's to be programmed.

Note: The park lights will flash once and the siren will chirp once each time a new code is learned.

Note: Transmitter programming must done quickly. Do not pause more than one second between each transmitter. **All the transmitters** to be used must be programmed at the same time. **All transmitters not programmed at this time will be erased from memory for security. The system holds a maximum of 4 transmitter codes including 2nd car remote codes.**

**If the Park Lights do not turn ON, turn ignition OFF, wait 5 seconds and repeat steps 1&2*

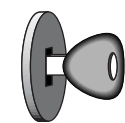

Ignition 3x
On/Off
On/Off On



Press and
HOLD the
Program
Button

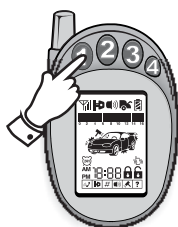

Press and
Release
Button # 1

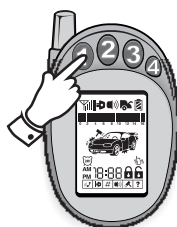

Press and
Release
Button # 1

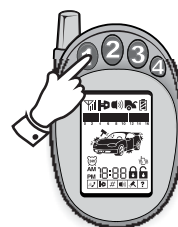

Press and
Release
Button # 1

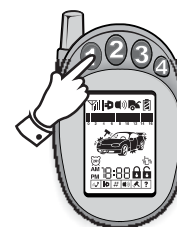

Press and
Release
Button # 1

Battery Replacement

When the Battery Icon on the remote indicates that the battery is low the battery should be changed promptly. Replace with quality 1.5volt "AAA" battery.

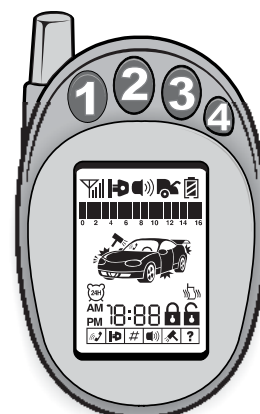
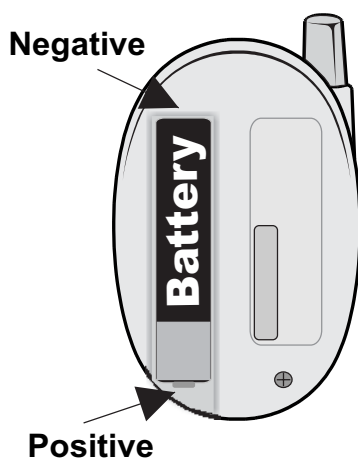

Negative Type Door Locks 250ma

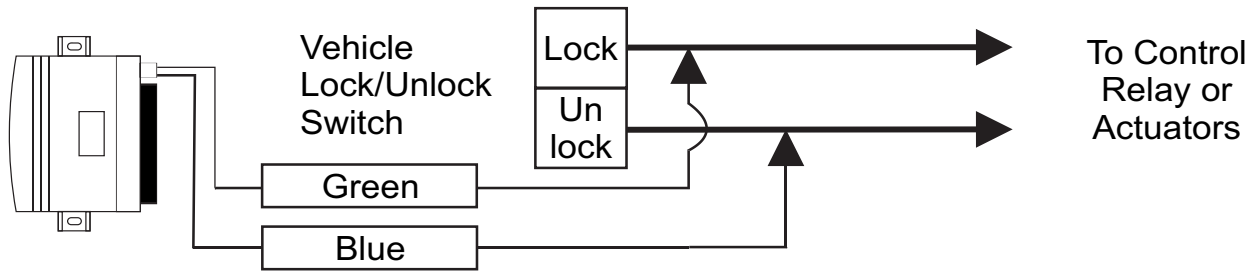

Negative Door Locks (More Than 250ma)

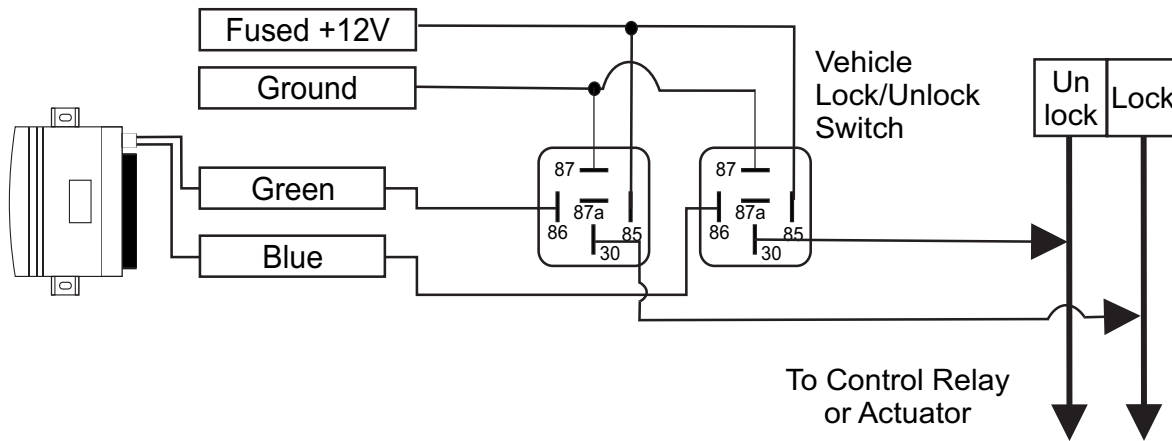

Positive Type Door Locks

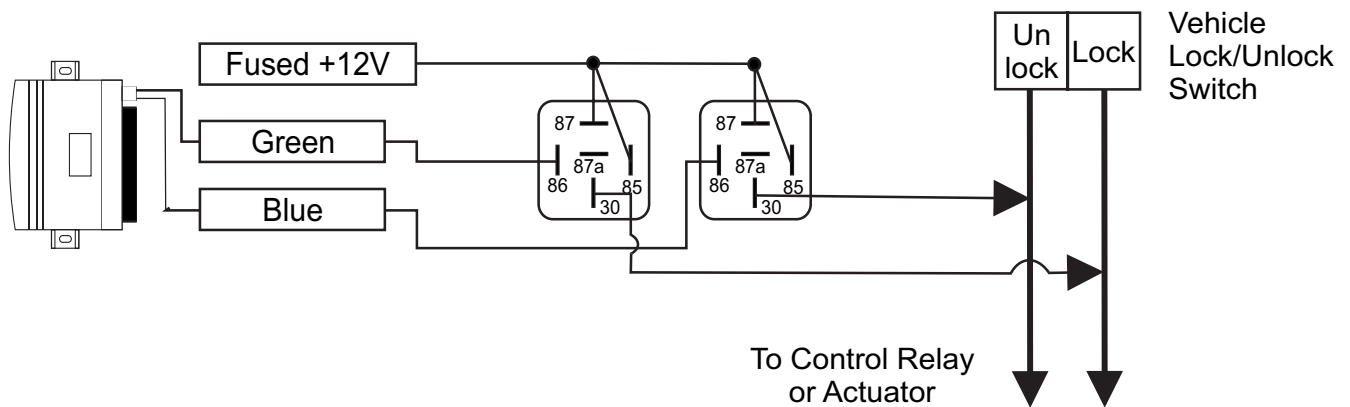

Note: When installing relays always use a fused power source.

5 Wire / Reverse Polarity Type Door Locks

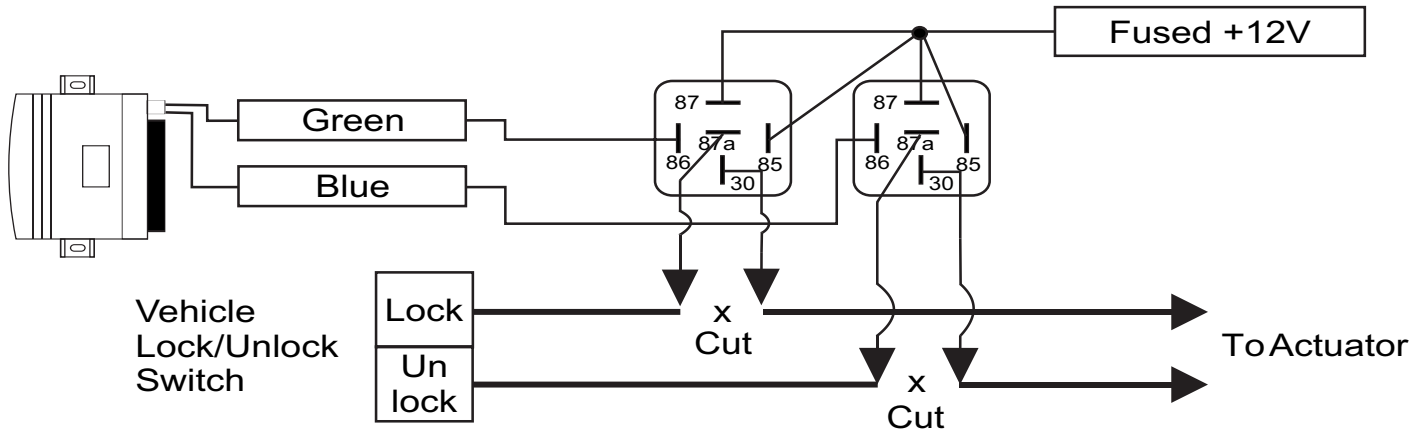

Aftermarket Doorlock Actuators

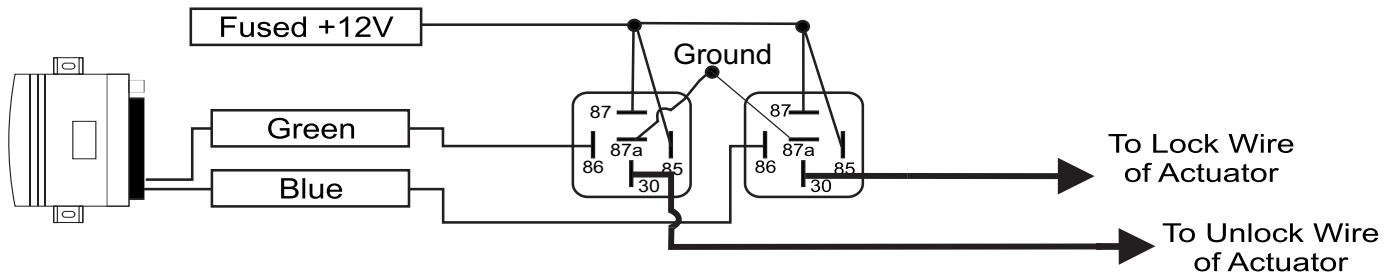

Vacuum Type Door Locks

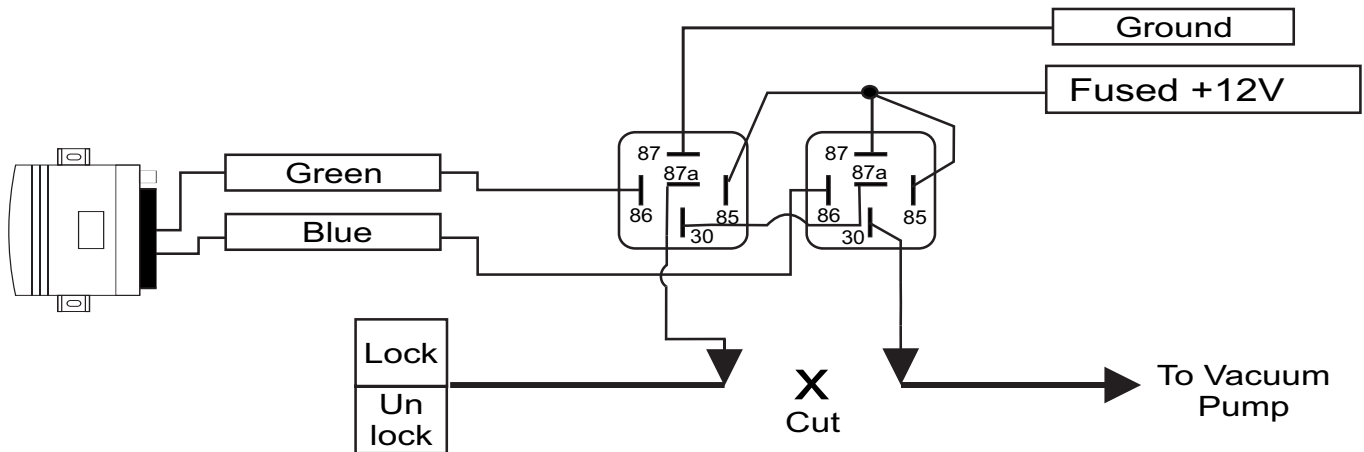

Note: When installing relays always use a fused power source.

DIAGNOSTICS

If the remote starter does not activate when the start button is pressed the park lights will flash a diagnostic to indicate what shutdown input has been triggered. For example when the start button is pressed the park lights flash 3 times slowly. Looking at the chart below this would indicate that the system is in Service Mode, simply follow the instructions listed in the owners manual on exiting Service Mode and the remote starter will begin to function as normal.

PARK LIGHTS STATUS LED

3 Flashes Series of 3 Flashes
3 Slow Flashes LED's On Solid
4 Slow Flashes Series of 4 Flashes
5 Flashes Series of 5 Flashes
5 Slow Flashes Series of 5 Flashes
6 Flashes Series of 6 Flashes
7 Flashes Series of 7 Flashes

DIAGNOSTIC CODE

Door Opened "M" Models
System Is In Service Mode
Not in Reservation Mode "M" units
Hood Pin Opened
Ignition On During Start Attempt
Brake Pedal Shutdown
Tach Lock-Out

DIAGNOSTIC MEMORY

LED Flashes

Diagnostic

5 Flashes The system was shutdown by the brake switch input
6 Flashes The system was shutdown by the hood pin input
7 Flashes The system did not detect the tach signal.
8 Flashes The system made 3 start attempts without starting

Being that the installer does not always see when the system shuts down or fails to start, Diagnostic Memory will store in memory up to four shutdown codes.

This information can then be accessed to determine the source of the shutdown.

To Enter Diagnostic Mode:

Step 1 - Turn the ignition on then turn off. Press the Program Button and release.

Step 2 - The system will respond with three park light flashes and the horn will honk (optional) the same number of times as the events in memory.

Maximum four events, four honks

NOTE: If the horn does not honk, there are no events in memory.

Step 3 - Press the Program Button once to view the last shut down code. The (optional) Horn will honk once to confirm code one.

If the horn does not honk, there are no codes in memory.

Step 4 - The LEDs on the antenna will flash a code corresponding to a shut down trigger. Press the Program Button again to check the second code.

The horn will honk twice to confirm code two.

Step 5 - To **Clear Diagnostic Memory**. While in Diagnostic Mode press and hold the Program Button for five seconds.

The park lights will flash and the horn(optional) will honk once.

NOTE: Once diagnostic memory has 4 shutdown events in memory, the system will not Record any further shutdown events until the system memory has been cleared.